

# 650V 10A Silicon Carbide Schottky Diode

## AKC65D010PAHH

### Features:

- Zero Reverse Recovery Current / Forward Recovery Voltage
- High Non-repetitive Peak Forward Surge Current ( $I_{FSM}$ )
- Low Forward Voltage ( $V_F$ )
- Low Leakage Current ( $I_R$ )
- RoHS Compliant (Note 1)
- Halogen-free (Note 1)

### Applications:

- Solar Inverters
- Industrial Power Supplies
- High Voltage DC/DC Converters
- Switch Mode Power Supplies
- Uninterruptible Power Supplies

### Key Performance Parameters:

Parameter	Value	Unit
$V_{RRM}$	650	V
$I_F$	10	A
$Q_C$	31	nC
$P_D$	125	W
$T_J$	175	°C

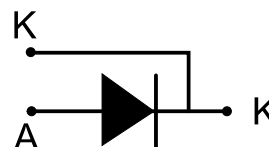
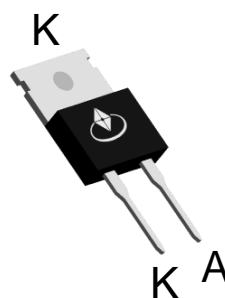

### Ordering Information:

Ordering Code	Package Type	Marking Code	Form	Packing
AKC65D010PAHH	TO-220-2L	C65D010PAHH	Tube	1000 per box

### Thermal Characteristics

Symbol	Parameter	Value	Units
$R_{\theta JC}$	Thermal Resistance, Junction-to-Case, Steady-State	1.2	°C/W

**Maximum Ratings** ( $T_A = 25\text{ }^\circ\text{C}$  unless otherwise noted)

Symbol	Parameter	Value	Units	
$V_{RRM}$	Repetitive Peak Reverse Voltage	650	V	
$I_F$	Continuous Forward Current	$T_C = 25\text{ }^\circ\text{C}$	31	A
		$T_C = 125\text{ }^\circ\text{C}$	17	A
		$T_C = 155\text{ }^\circ\text{C}$	10	A
$I_{FRM}$	Repetitive Peak Forward Surge Current	$T_C = 25\text{ }^\circ\text{C}$ , $t_p = 10\text{ ms}$ , Half Sine Wave	40	A
		$T_C = 110\text{ }^\circ\text{C}$ , $t_p = 10\text{ ms}$ , Half Sine Wave	32	A
$I_{FSM}$	Non-repetitive Peak Forward Surge Current	$T_C = 25\text{ }^\circ\text{C}$ , $t_p = 10\text{ ms}$ , Half Sine Wave	85	A
		$T_C = 110\text{ }^\circ\text{C}$ , $t_p = 10\text{ ms}$ , Half Sine Wave	72	A
$I_{F,max}$	Non-repetitive Peak Forward Surge Current	$T_C = 25\text{ }^\circ\text{C}$ , $t_p = 10\text{ }\mu\text{s}$ , Pulse	910	A
		$T_C = 110\text{ }^\circ\text{C}$ , $t_p = 10\text{ }\mu\text{s}$ , Pulse	690	A
$P_D$	Power Dissipation	$T_C = 25\text{ }^\circ\text{C}$	125	W
		$T_C = 110\text{ }^\circ\text{C}$	54	W
$T_J$	Operating Junction Temperature	175	$^\circ\text{C}$	
$T_{STG}$	Storage Temperature	-55~175	$^\circ\text{C}$	

**Electrical Characteristics** ( $T_J = 25^\circ\text{C}$  unless otherwise noted)

Symbol	Parameter	Test Conditions	Min	Typ	Max	Units
$V_{BR}$	Reverse Breakdown Voltage	$I_R = 100 \mu\text{A}$	650	-	-	V
$V_F$	Forward Voltage	$I_F = 10 \text{ A}, T_J = 25^\circ\text{C}$	-	1.38	1.50	V
		$I_F = 10 \text{ A}, T_J = 175^\circ\text{C}$	-	1.85	2.0	V
$I_R$	Reverse Leakage Current	$V_R = 650 \text{ V}, T_J = 25^\circ\text{C}$	-	10	50	$\mu\text{A}$
		$V_R = 650 \text{ V}, T_J = 175^\circ\text{C}$	-	20	150	$\mu\text{A}$
$Q_C$	Total Capacitive Charge	$V_R = 400 \text{ V},$ $Q_C = \int_0^{V_R} C(V_R) dV(V_R)$	-	31	-	nC
C	Total Capacitance	$V_R = 0 \text{ V}, f = 100 \text{ kHz}$ $T_J = 25^\circ\text{C}$	-	560	-	pF
		$V_R = 400 \text{ V}, f = 100 \text{ kHz}$ $T_J = 25^\circ\text{C}$	-	47	-	pF
$E_C$	Capacitance Stored Energy	$V_R = 400 \text{ V}$	-	4.5	-	$\mu\text{J}$

**Notes:**

1. Contact ALKAIDSEMI sales for detail information

## Electrical Characteristics Diagrams

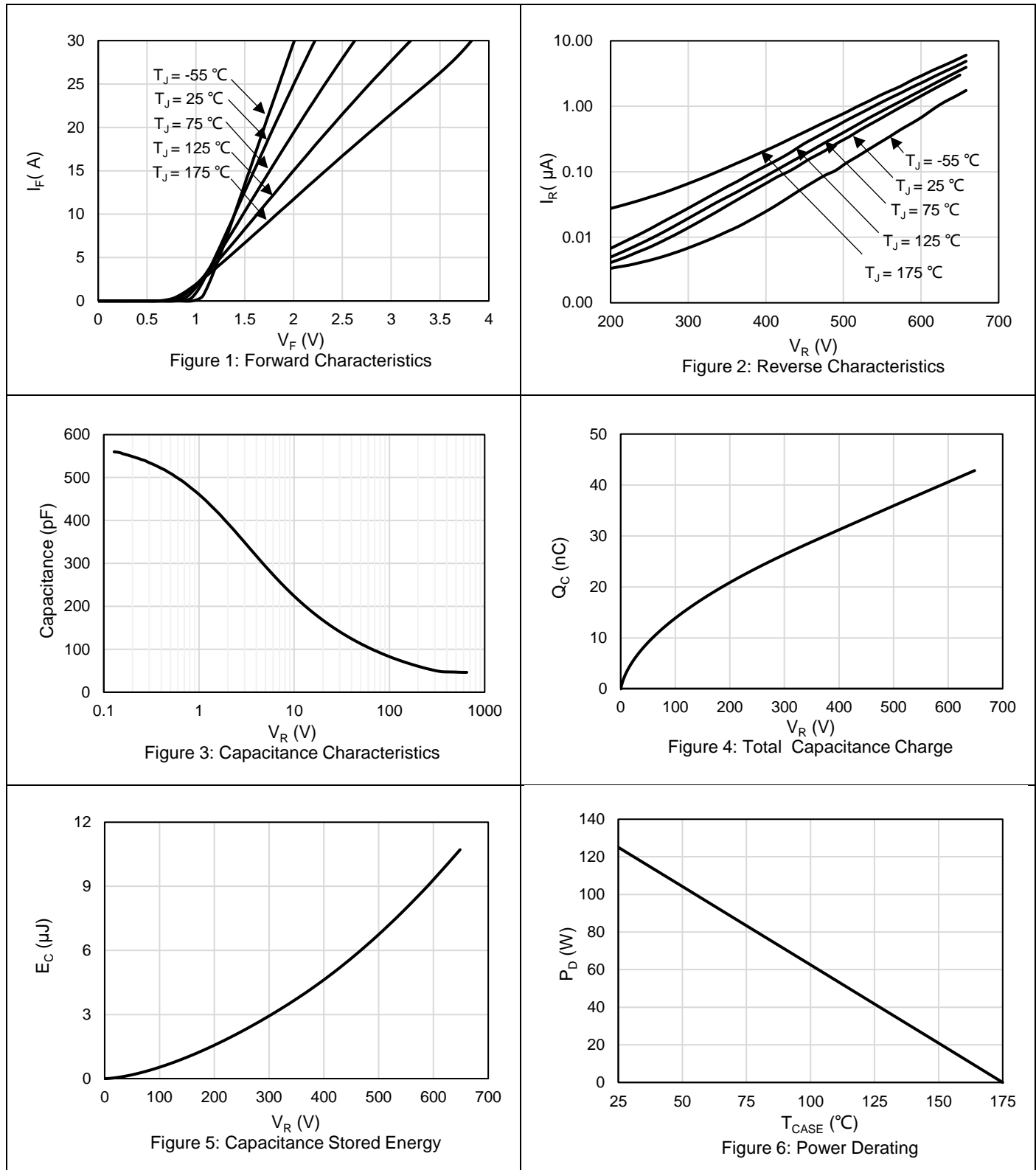

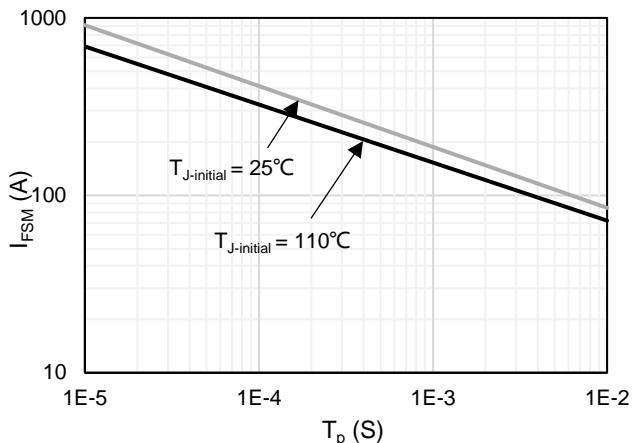

Figure 7:  $I_{FSM}$  vs. Pulse duration

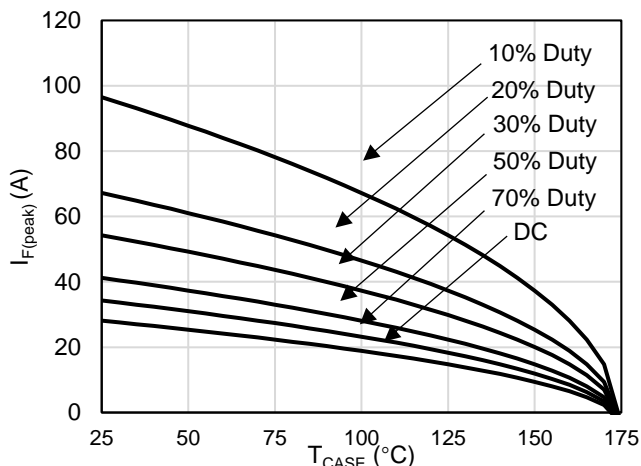

Figure 8: Current De-rating

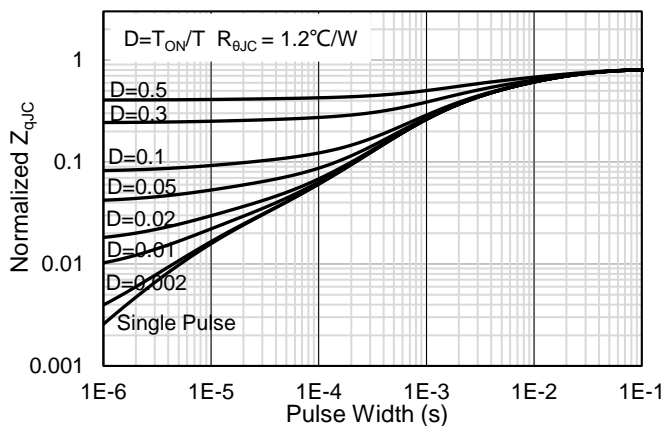
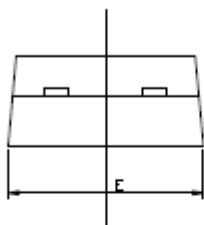
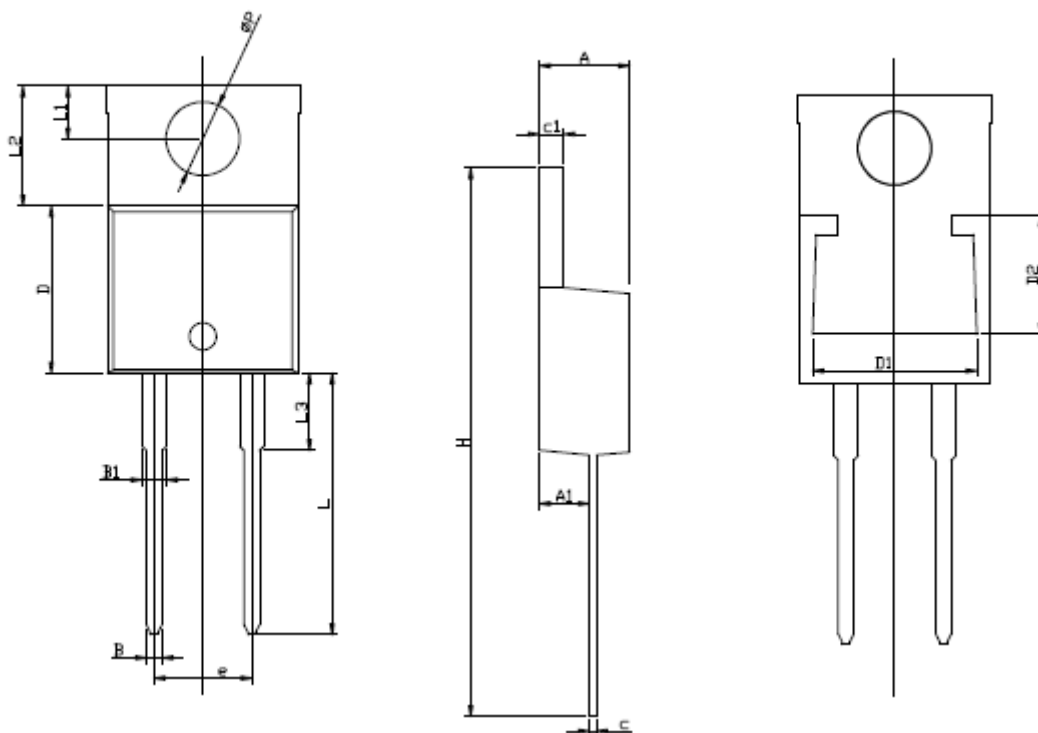

Figure 9: Normalized Maximum Transient Thermal Impedance

# Package Outlines

## TO-220AD-2L PACKAGE OUTLINE



RECOMMENDED LAND PATTERN

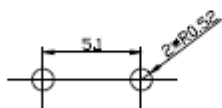

UNIT: mm

	MIN	NOM	MAX
A	4.50	4.70	4.90
A1	2.45	2.60	2.70
B	0.72	0.82	0.92
B1	1.12	1.27	1.42
c	0.28	0.38	0.48
c1	1.17	1.27	1.37
D	8.46	8.66	8.86
D1	7.70	7.90	8.40
D2	5.00	5.20	5.40
e		5.10	
E	9.85	10.15	10.45
H	28.00	28.50	29.00
ΦP		3.84	
L	13.1	13.6	14.1
L1	2.54	2.74	2.94
L2	6.04	6.24	6.44
L3	3.85	4.05	4.35

## Marking Information

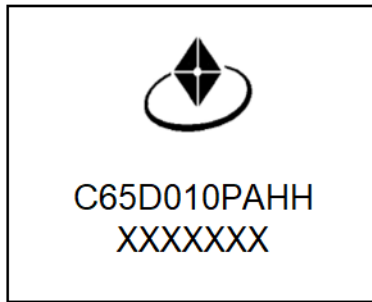

Note:

C65D010PAHH = Product Name Code

XXXXXXX = Date code

Contact ALKAIDSEMI sales for detail information

## Revision History

Revision	Release Date	Remark
Rev.1.5	2022-07-28	

## Disclaimer

The information given in this document describes the independent performance of the product, but similar performance is not guaranteed under other working conditions, and cannot be guaranteed when installed with other products or equipment. To achieve the required performance of the product in actual scenarios, the customer should conduct a complete application test to assess the functionality of the product.

Alkaidsemi assumes no responsibility for equipment failures result from using products at values that exceed the ratings, operating conditions, or other parameters listed in the product specifications.

The product described in this specification is not applicable for aerospace or other applications which requires high reliability. Customers using or selling these products for use in medical, life-saving, or life-sustaining applications do so at their own risk and agree to fully indemnify.

Due to product or technical improvements, the information described or contained herein may be changed without prior notice.