

40V 1.1mohm N-channel SGT MOSFET

AKG40N011G

Description:

This N channel SGT MOSFET has been designed to ultra-low on-state resistance ($R_{DS(on)}$) and yet maintain superior switching performance, especially for high efficiency power management applications.

Features:

- N-channel, optimized for high-speed smooth switching
- Excellent Gate Charge $\times R_{DS(on)}$ (FOM)
- Ultra-low on-resistance
- RoHS compliant (Note 1)
- Halogen-free (Note 1)

Applications:

- Power Management
- Motor Drivers
- DC-DC Converters

Key Performance Parameters:

Parameter	Value	Unit
V_{DS}	40	V
$R_{DS(on), max} @ V_{GS}=10V$	1.1	m Ω
I_D	200	A

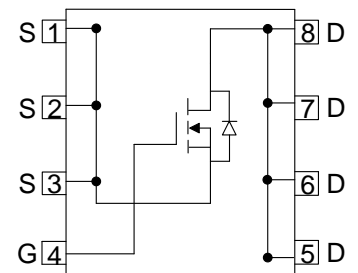
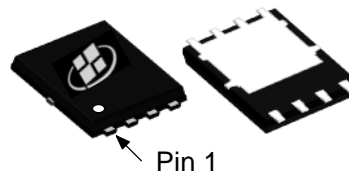

Ordering Information:

Ordering Code	Package Type	Marking Code	Form	Packing
AKG40N011G	PDFN5X6-8L	AKG40N011G	13 inches Reel	5000

Notes:

1. Contact ALKAIDSEMI sales for detail information

Maximum Ratings ($T_A = 25\text{ °C}$ unless otherwise noted)

Symbol	Parameter	Value	Units
V_{DS}	Drain-Source Voltage	40	V
I_D	Drain Current - Continuous ($T_C = 25\text{ °C}$)	200	A
	Drain Current -Continuous ($T_C = 100\text{ °C}$)	130	A
I_{DM}	Drain Current - Pulsed (Note 1,2)	600	A
V_{GS}	Gate-Source Voltage	± 20	V
E_{AS}	Single Pulsed Avalanche Energy (Note 3)	441	mJ
P_D	Power Dissipation ($T_C = 25\text{ °C}$)	67.5	W
T_J, T_{STG}	Operating and Storage Temperature Range	-55 to +150	$^{\circ}\text{C}$

Thermal Characteristics

Symbol	Parameter	Value	Units
$R_{\theta JC}$	Thermal Resistance, Junction-to-Case, Steady-State	1.85	$^{\circ}\text{C/W}$
$R_{\theta JA}$	Thermal Resistance, Junction-to-Ambient Steady State (Note 4)	50.2	$^{\circ}\text{C/W}$

Notes:

1. The max drain current rating is package limited
2. Repetitive Rating: Pulse width limited by maximum junction temperature
3. $L = 0.5\text{ mH}$, $V_{DD} = 20\text{ V}$, $I_{AS} = 42\text{ A}$, $R_G = 25\ \Omega$, Starting $T_J = 25\text{ °C}$
4. Mount on minimum PCB layout
5. Essentially independent of operating temperature

Electrical Characteristics ($T_J = 25^\circ\text{C}$ unless otherwise noted)

Symbol	Parameter	Test Conditions	Min	Typ	Max	Units
Static Characteristics						
BV_{DSS}	Drain-Source Breakdown Voltage	$V_{GS} = 0\text{ V}, I_D = 250\ \mu\text{A}$	40			V
I_{DSS}	Zero Gate Voltage Drain Current	$V_{DS} = 40\text{ V}, V_{GS} = 0\text{ V}, T_J = 25^\circ\text{C}$			1	μA
		$V_{DS} = 40\text{ V}, V_{GS} = 0\text{ V}, T_J = 150^\circ\text{C}$			250	
I_{GSS}	Gate Leakage Current	$V_{GS} = \pm 20\text{ V}, V_{DS} = 0\text{ V}$			± 100	nA
$V_{GS(TH)}$	Gate Threshold voltage	$V_{DS} = V_{GS}, I_D = 250\ \mu\text{A}$	1.2	1.7	2.2	V
$R_{DS(ON)}$	Drain-Source on-state resistance	$V_{GS} = 10\text{ V}, I_D = 30\text{ A}$		0.9	1.1	m Ω
		$V_{GS} = 4.5\text{ V}, I_D = 30\text{ A}$		1.3	1.5	
G_{FS}	Forward Transconductance	$V_{DS} = 5\text{ V}, I_D = 20\text{ A}$		110		S
Dynamic Characteristics						
C_{ISS}	Input capacitance	$V_{DS} = 20\text{ V}, V_{GS} = 0\text{ V}, F = 1\text{ MHz}$		5480		pF
C_{OSS}	Output capacitance			1770		pF
C_{RSS}	Reverse transfer capacitance			22		pF
R_G	Gate resistance	$F = 1\text{ MHz}$		5.7		Ω
Switching Characteristics						
$T_{D(ON)}$	Turn On Delay Time	$V_{DS} = 20\text{ V}, I_D = 20\text{ A}, V_{GS} = 10\text{ V}, R_{GEN} = 11\ \Omega$ (Note 5)		15		ns
T_R	Rise Time			38		ns
$T_{D(OFF)}$	Turn Off Delay Time			183.2		ns
T_F	Fall Time			123.4		ns
Q_G	Total Gate Charge	$V_{DS} = 32\text{ V}, I_D = 20\text{ A}, V_{GS} = 10\text{ V}$ (Note 5)		81.4		nC
Q_{GS}	Gate-Source Charge			20.6		nC
Q_{GD}	Gate-Drain Charge			6.2		nC
Drain-Source Diode Characteristics and Maximum Ratings						
I_S	Maximum Continuous Body-Diode Forward Current			200		A
I_{SM}	Maximum Pulsed Body-Diode Forward Current (NOTE 1)			800		A
V_{SD}	Diode Forward Voltage	$V_{GS} = 0\text{ V}, I_S = 30\text{ A}$		0.79		V
T_{RR}	Reverse recovery time	$I_F = 20\text{ A}, di/dt = 100\text{ A}/\mu\text{S}$		17		ns
Q_{RR}	Reverse recovery charge				4	

Electrical Characteristics Diagrams

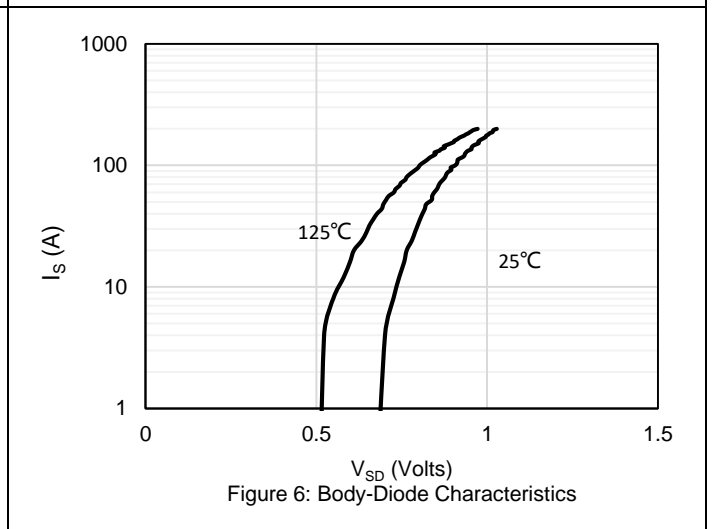
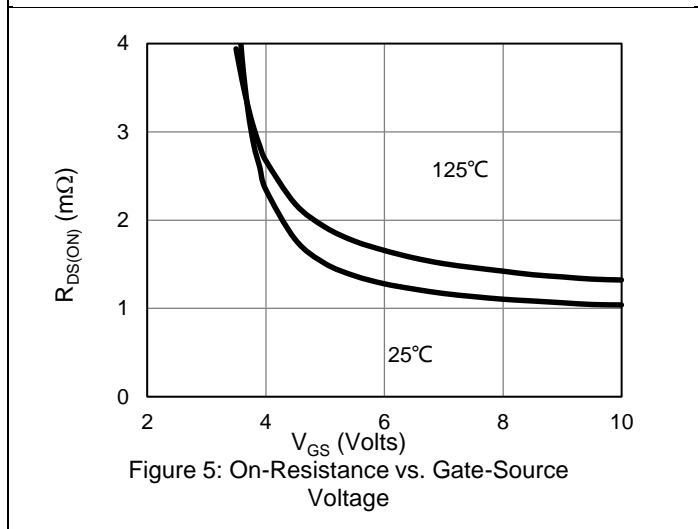
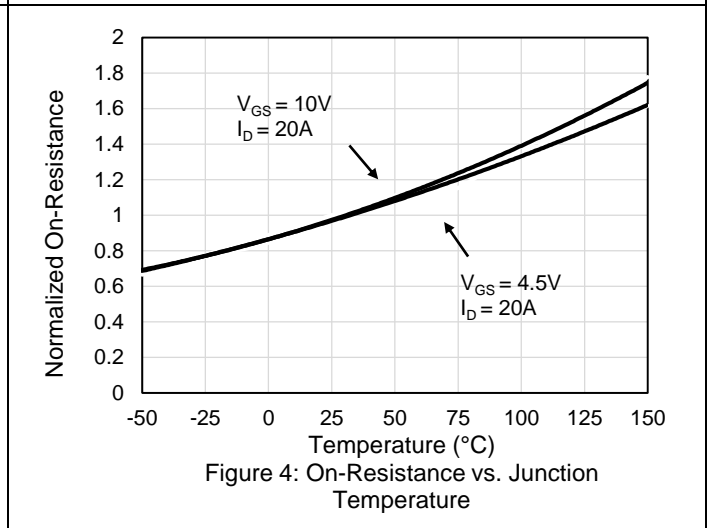
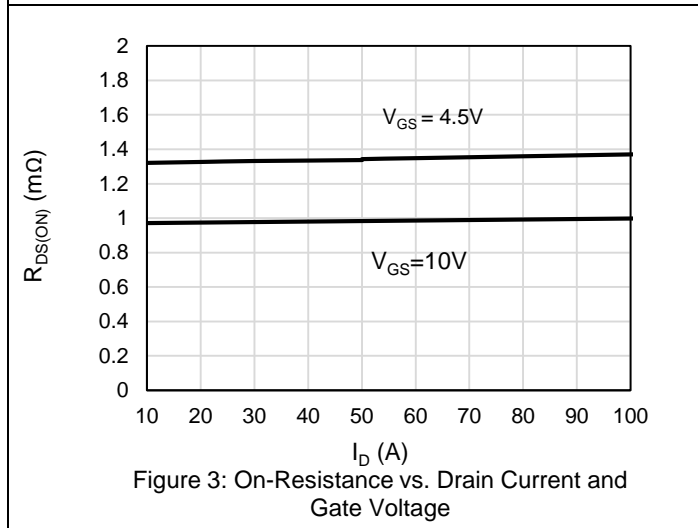
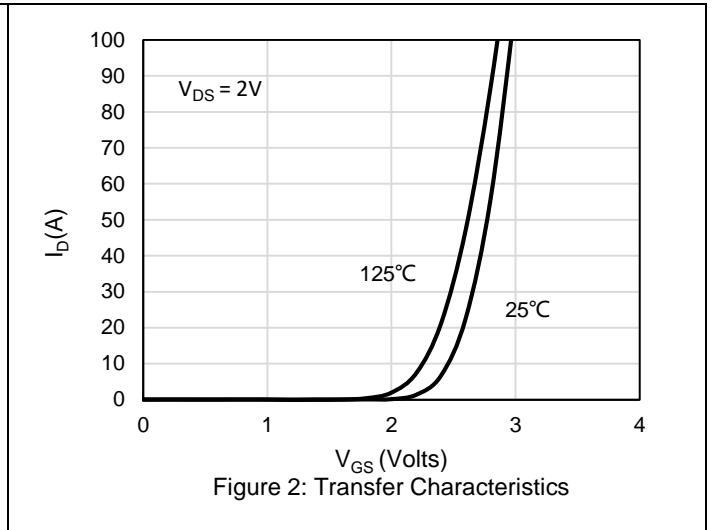
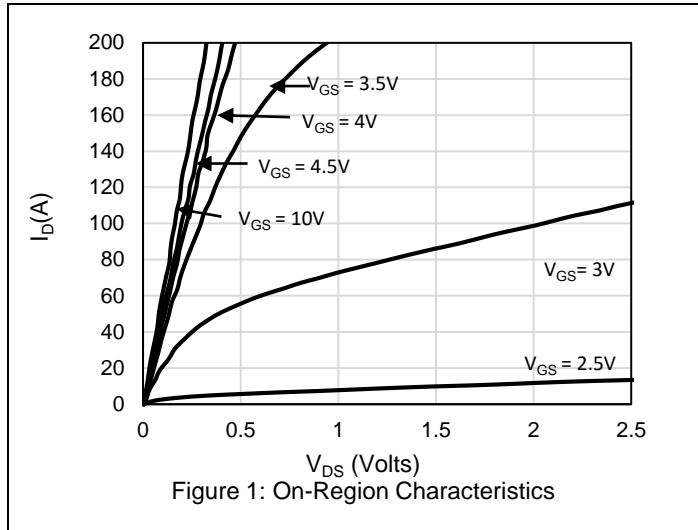

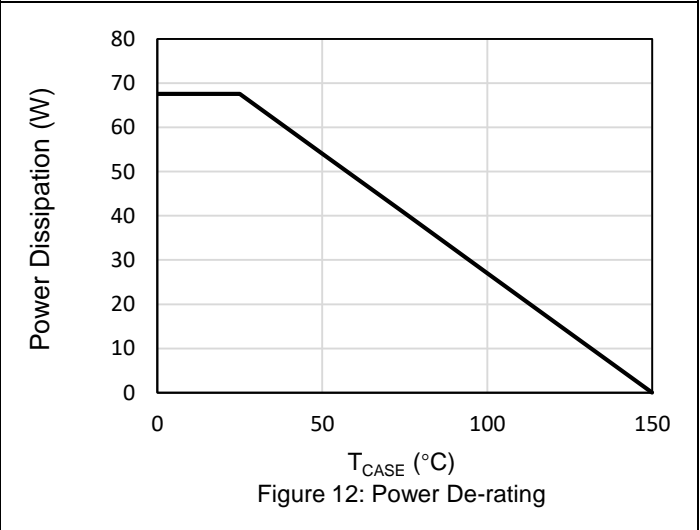
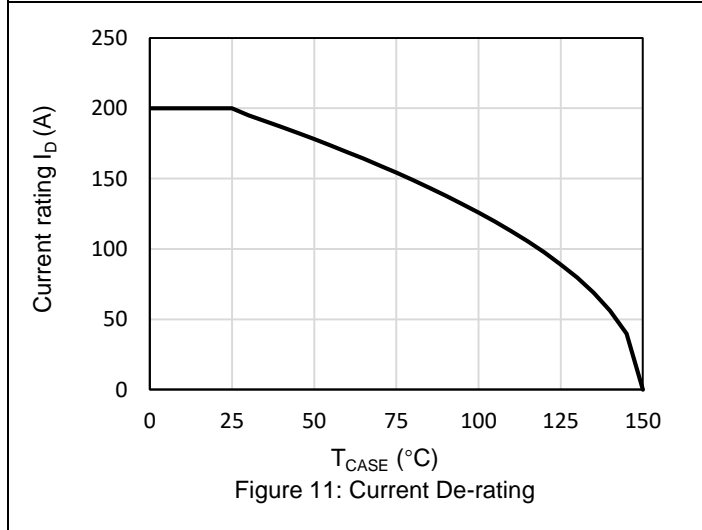
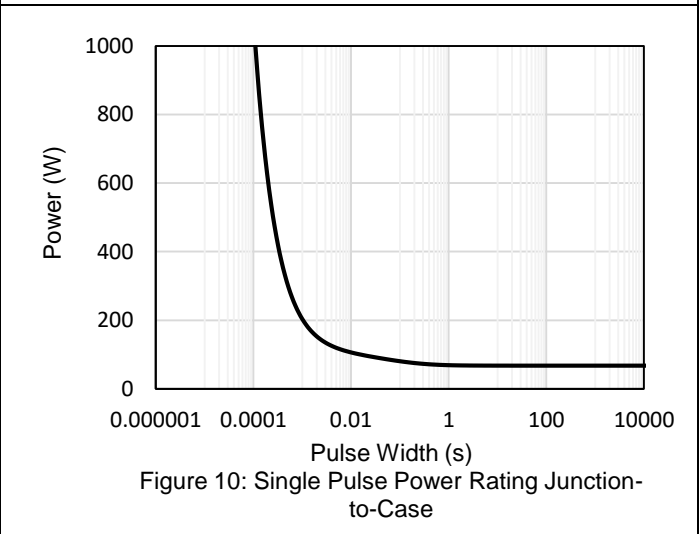
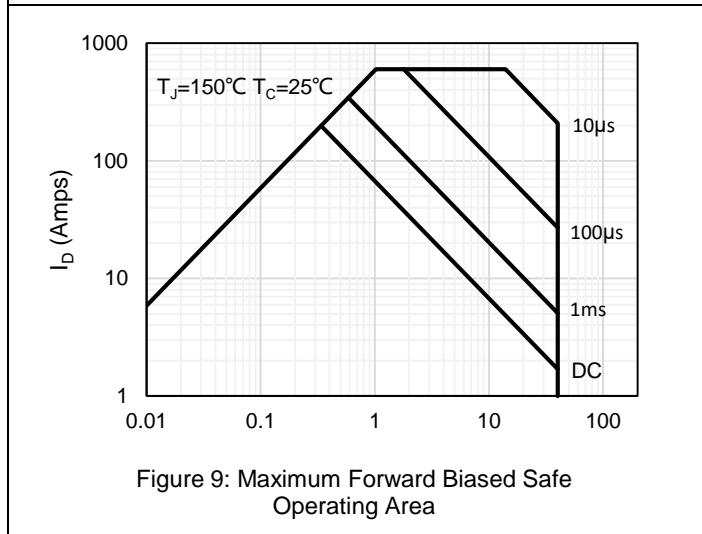
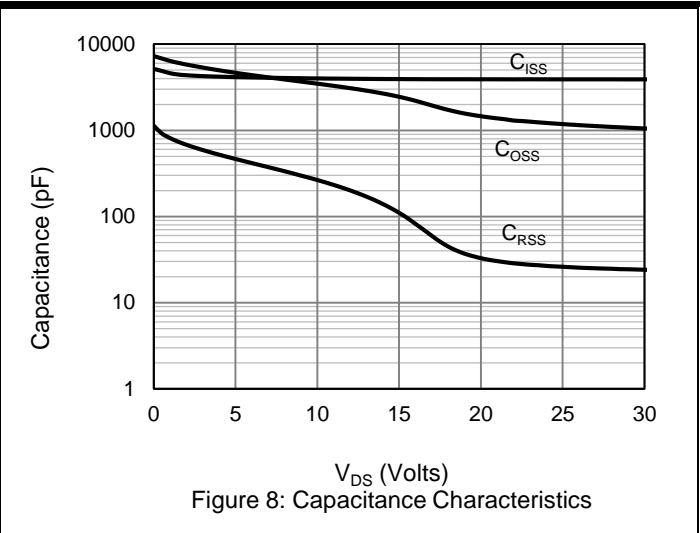
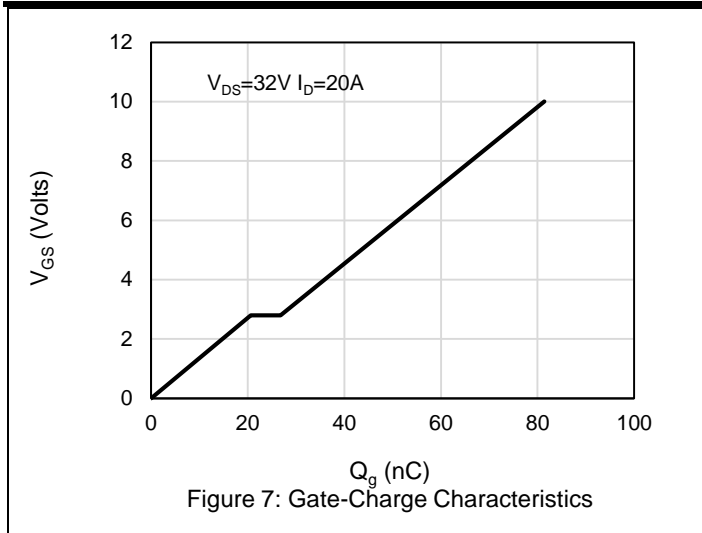

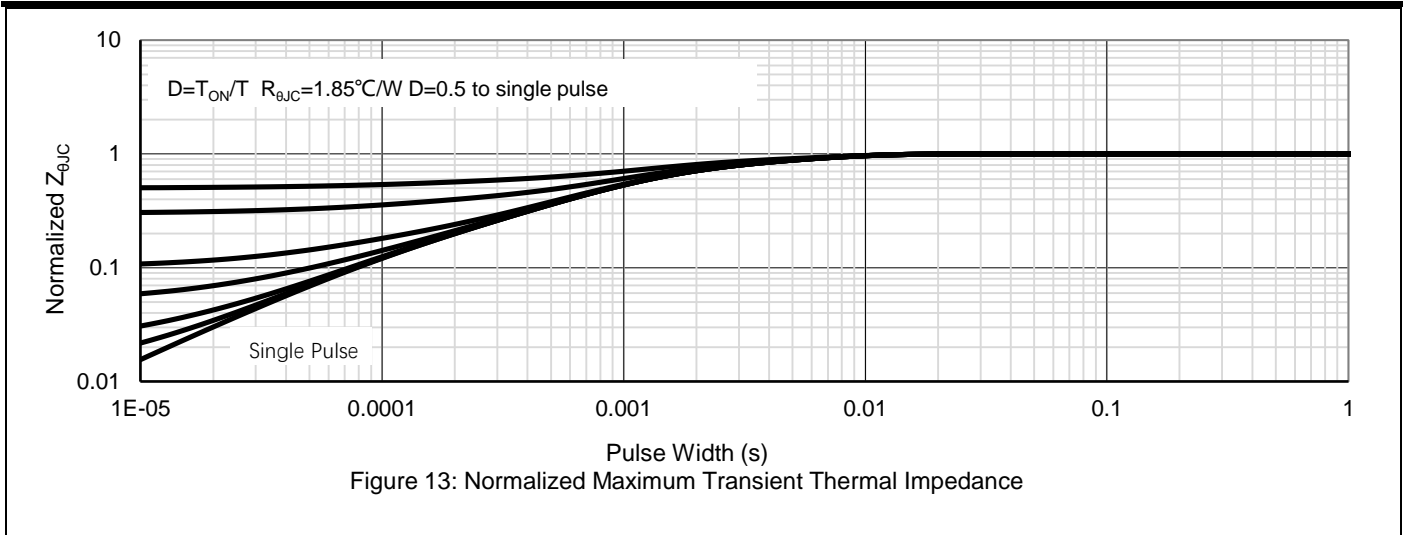

Package Outlines

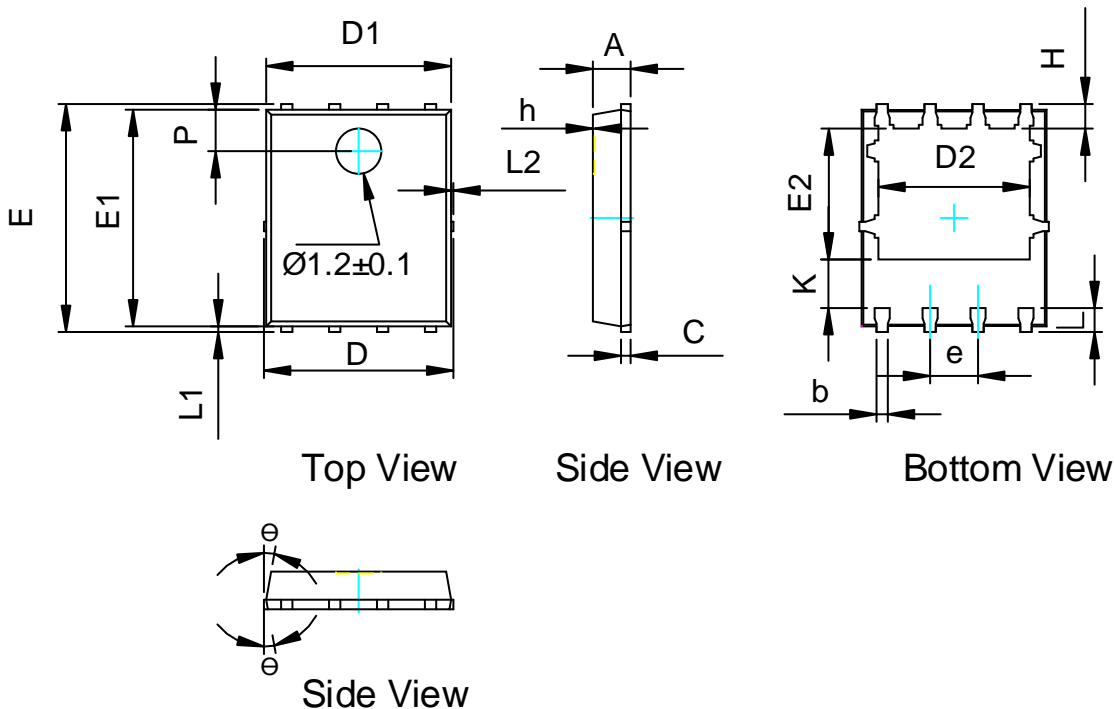

SYMBOL	MIN	NOM	MAX
A	0.90	1.00	1.10
b	0.20	0.30	0.40
c	0.21	0.25	0.34
D	-	-	5.10
D1	4.80	4.90	5.00
D2	3.91	4.01	4.11
e	1.27 BSC		
E	5.90	6.00	6.10
E1	5.65	5.75	5.85
E2	3.375	3.475	3.575
H	0.55	0.65	0.75
h	-	-	0.05
K	1.20	-	-
L	0.55	0.65	0.75
L1	0.05	0.15	0.25
L2	-	-	0.12
θ	8°	10°	12°
P	1.00	1.10	1.20

COMMON DIMENSIONS
(UNITS OF MEASURE = MILLIMETER)

Test Circuit and Waveform

Gate Charge Test Circuit & Waveform

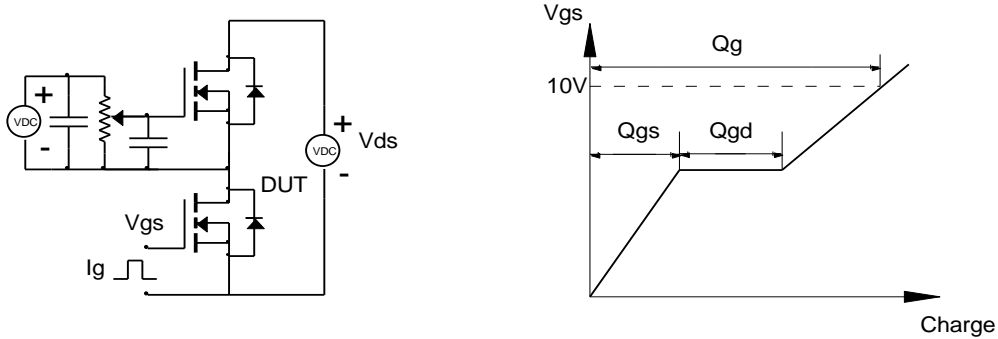

Resistive Switching Test Circuit & Waveforms

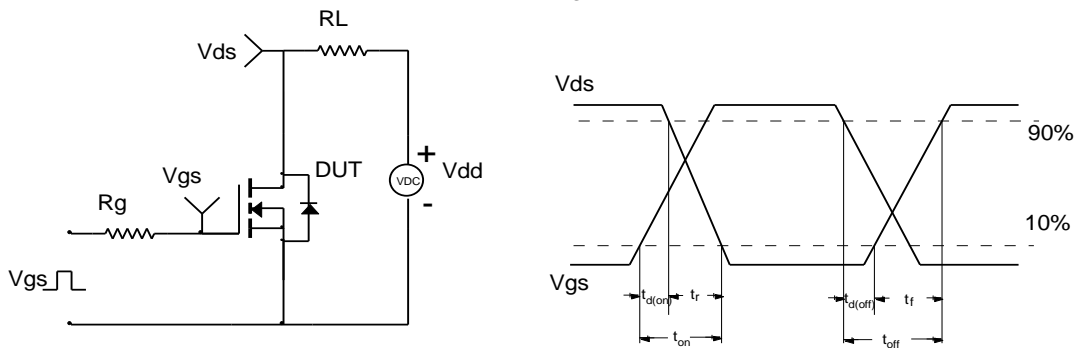

Unclamped Inductive Switching (UIS) Test Circuit & Waveforms

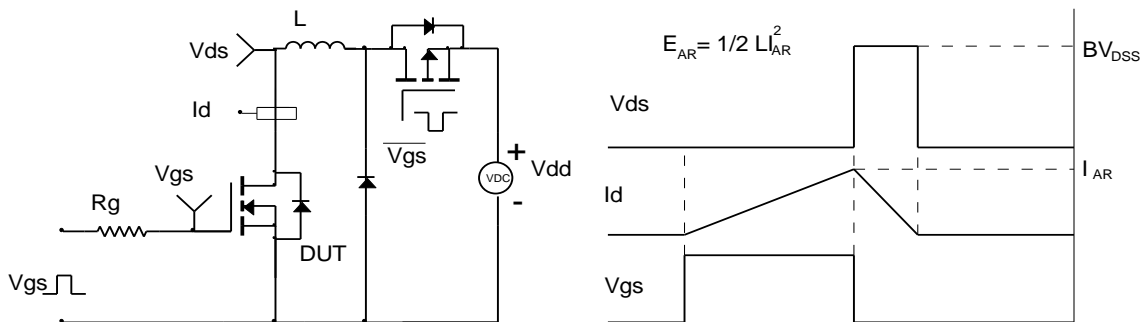

Diode Recovery Test Circuit & Waveforms

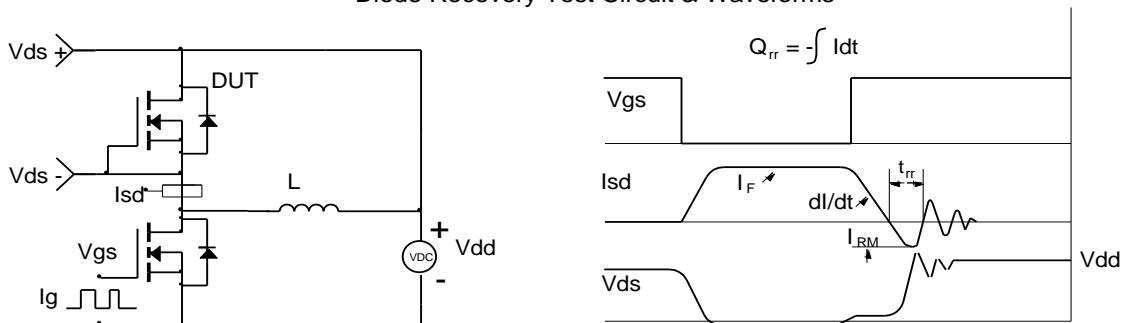

Marking Information

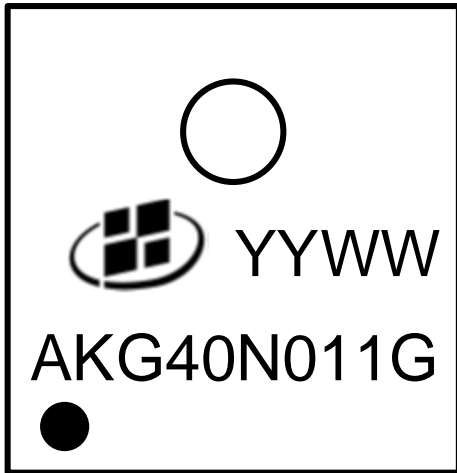

Note:

YYWW = Date code

AKG40N011G = Product Name Code

Contact ALKAIDSEMI sales for detail information

Reel and Tube Information

REEL DIMENSIONS

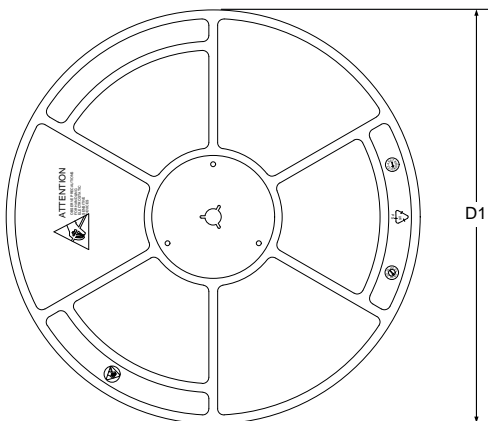

TAPE DIMENSIONS

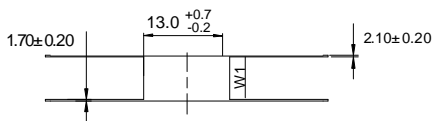
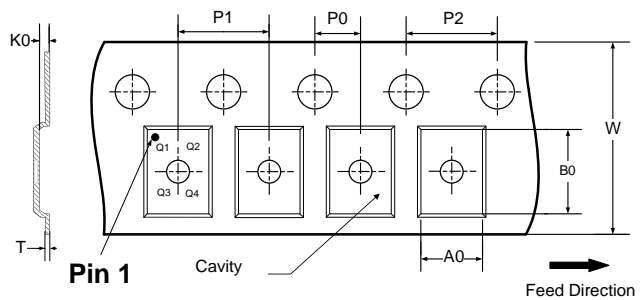

- A0: Dimension designed to accommodate the component width
- B0: Dimension designed to accommodate the component length
- K0: Dimension designed to accommodate the component thickness
- W: Overall width of the carrier tape
- P0: Pitch between successive cavity centers and sprocket hole
- P1: Pitch between successive cavity centers
- P2: Pitch between sprocket hole
- T: Tape material thickness
- D1: Reel Diameter
- W1: Reel Width

DIMENSIONS										(Unit: mm)
Reel	D1	W1								Material
	330	12.5								Hips
Tape	P0	P1	P2	W	A0	B0	K0	T	Pin 1 Quadrant	Material
	4	8	2	12	6.3	5.3	1.2	0.25	Q1	PC

All dimensions are nominal

Revision History

Revision	Release Date	Remark
Rev.1.5	2021-11-24	Initial release

Disclaimer

The information given in this document describes the independent performance of the product, but similar performance is not guaranteed under other working conditions, and cannot be guaranteed when installed with other products or equipment. To achieve the required performance of the product in actual scenarios, the customer should conduct a complete application test to assess the functionality of the product.

Alkaidsemi assumes no responsibility for equipment failures result from using products at values that exceed the ratings, operating conditions, or other parameters listed in the product specifications.

The product described in this specification is not applicable for aerospace or other applications which requires high reliability. Customers using or selling these products for use in medical, life-saving, or life-sustaining applications do so at their own risk and agree to fully indemnify.

Due to product or technical improvements, the information described or contained herein may be changed without prior notice.