

40V 2.5mohm N-channel SGT MOSFET AKG4N025GM-A

Description:

This device is designed for automotive applications and manufactured in IATF16949 certified facilities. Qualified AEC-Q101.

Features:

- LOW $R_{DS(ON)}$
- RoHS compliant ^(Note 1)
- 175°C Operating Temperature
- Halogen-free ^(Note 1)
- 100% UIS Tested
- AEC-Q101 qualified

Applications:

- Battery Management System
- Motor Drivers
- DC-DC Converter

Key Performance Parameters:

Parameter	Value	Unit
V_{DS}	40	V
$R_{DS(ON), max} @V_{GS} = 10V$	2.5	m Ω
I_D	130	A

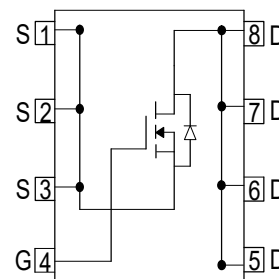
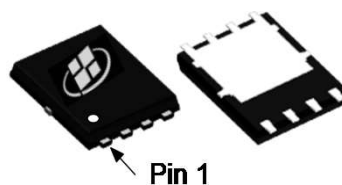

Ordering Information:

Ordering Code	Package Type	Marking Code	Form	Packing
AKG4N025GM-A	PDFN5X6	G4N025GM	Tape Reel	5000PCS

Notes:

1. Contact ALKAIDSEMI sales for detail information

Maximum Ratings $(T_A = 25^\circ\text{C}$ unless otherwise noted)

Symbol	Parameter	Value	Units
V_{DS}	Drain-Source Voltage	40	V
I_D	Drain Current - Continuous $(T_C = 25^\circ\text{C})$ ^(Note 1)	130	A
	Drain Current - Continuous $(T_C = 100^\circ\text{C})$	92	A
I_{DM}	Drain Current - Pulsed ^(Note 2)	520	A
V_{GS}	Gate-Source Voltage	± 20	V
E_{AS}	Single Pulsed Avalanche Energy ^(Note 3)	256	mJ
P_D	Power Dissipation $(T_C = 25^\circ\text{C})$	75	W
T_J, T_{STG}	Operating and Storage Temperature Range	-55 to +175	$^\circ\text{C}$

Thermal Characteristics

Symbol	Parameter	Value	Units
$R_{\theta JC}$	Thermal Resistance, Junction-to-Case, Steady-State	2	$^\circ\text{C}/\text{W}$
$R_{\theta JA}$	Thermal Resistance, Junction-to-Ambient, Steady State ^(Note 4)	45	$^\circ\text{C}/\text{W}$

Notes:

1. The max drain current rating is silicon limited
2. Repetitive Rating: Pulse width limited by maximum junction temperature
3. $L = 0.5$ mH, $V_{DD} = 20$ V, $I_{AS} = 32$ A, $R_G = 25$ Ω , Starting $T_J = 25$ $^\circ\text{C}$
4. Mount on minimum PCB layout

Electrical Characteristics ($T_J = 25^\circ\text{C}$ unless otherwise noted)

Symbol	Parameter	Test Conditions	Min	Typ	Max	Units
--------	-----------	-----------------	-----	-----	-----	-------

Static Characteristics

BV_{DSS}	Drain-Source Breakdown Voltage	$V_{GS} = 0\text{ V}, I_D = 250\ \mu\text{A}$	40			V
I_{DSS}	Zero Gate Voltage Drain Current	$V_{DS} = 40\text{ V}, V_{GS} = 0\text{ V},$			1	μA
I_{GSS}	Gate Leakage Current	$V_{GS} = \pm 20\text{ V}, V_{DS} = 0\text{ V}$			± 100	nA
$V_{GS(TH)}$	Gate Threshold voltage	$V_{DS} = V_{GS}, I_D = 250\ \mu\text{A}$	2	3	4	V
$R_{DS(ON)}$	Drain-Source on-state resistance	$V_{GS} = 10\text{ V}, I_D = 20\text{ A}$		2.1	2.5	m Ω

Dynamic Characteristics

C_{ISS}	Input Capacitance	$V_{DS} = 20\text{ V}, V_{GS} = 0\text{ V},$ $F = 1\text{ MHz}$		3055		pF
C_{OSS}	Output Capacitance			862		pF
C_{RSS}	Reverse Transfer Capacitance			29		pF
$T_{D(ON)}$	Turn On Delay Time	$V_{DD} = 20\text{ V}, R_L = 0.23\ \Omega,$ $V_{GS} = 10\text{ V}, R_G = 3.9\ \Omega$		14		nS
T_R	Rise Time			45		nS
$T_{D(OFF)}$	Turn Off Delay Time			33		nS
T_F	Fall Time			14		nS
Q_G	Total Gate Charge	$V_{DD} = 32\text{ V}, I_D = 100\text{ A},$ $V_{GS} = 10\text{ V}$		36		nC
Q_{GS}	Gate-Source Charge			18		nC
Q_{GD}	Gate-Drain Charge			7		nC

Drain-Source Diode Characteristics and Maximum Ratings

I_S	Maximum Continuous Body-Diode Forward Current				130	A
I_{SM}	Maximum Pulsed Body-Diode Forward Current ^(NOTE 1)				520	A
V_{SD}	Diode Forward Voltage	$V_{GS} = 0\text{ V}, I_S = 50\text{ A}$		0.84		V
T_{RR}	Reverse recovery time	$V_{DD} = 32\text{ V}, I_D = 50\text{ A},$ $di/dt = 100\text{ A}/\mu\text{S}$		38		nS
Q_{RR}	Reverse recovery charge			35		nC
I_{RRM}	Peak Reverse Recovery Current			1.6		A

Electrical Characteristics Diagrams

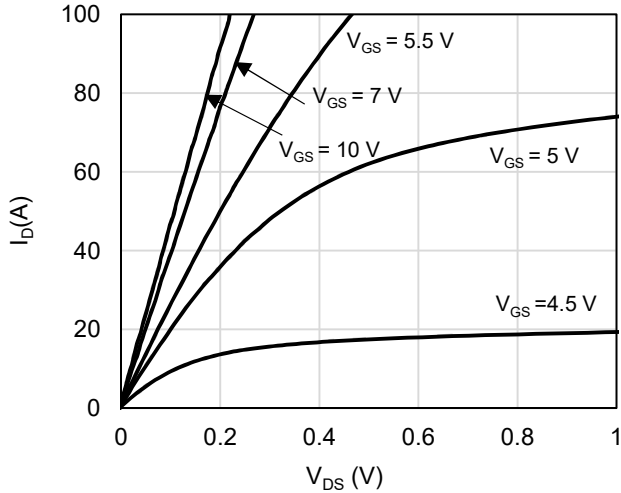

Figure 1: On-Region Characteristics

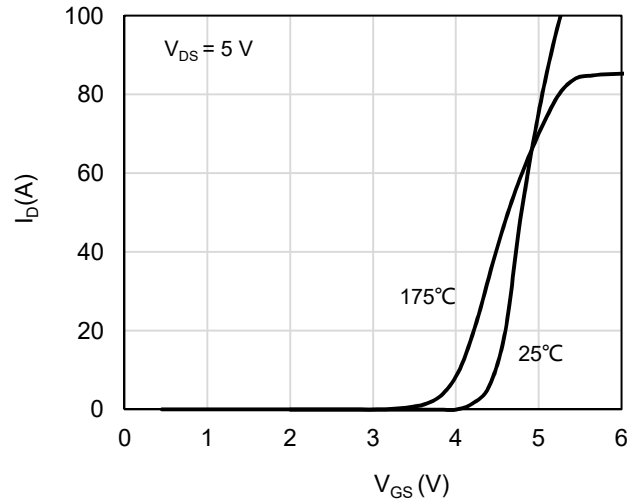

Figure 2: Transfer Characteristics

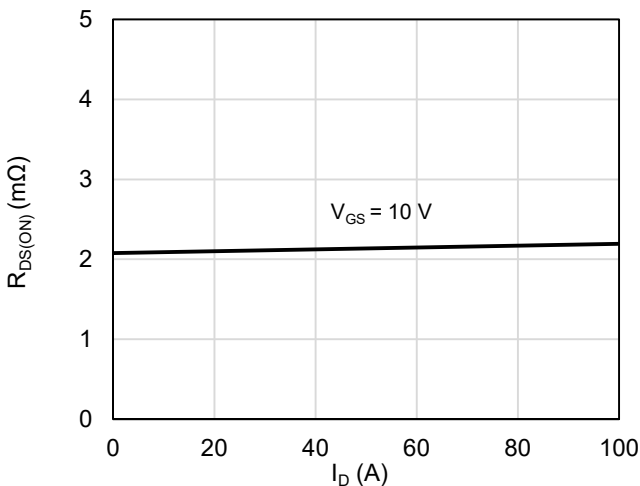

Figure 3: On-Resistance vs. Drain Current and Gate Voltage

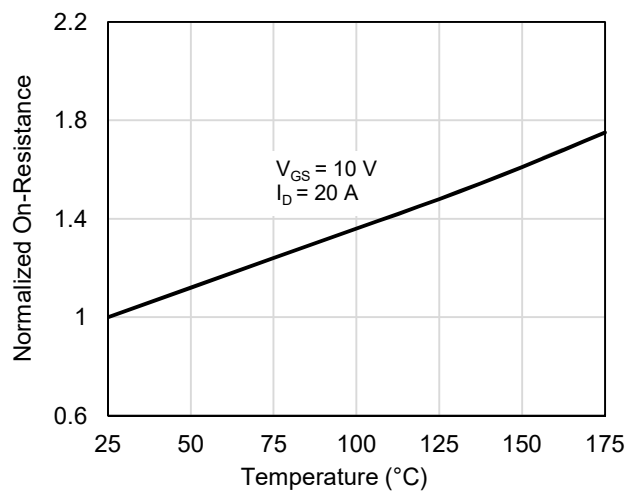

Figure 4: On-Resistance vs. Junction Temperature

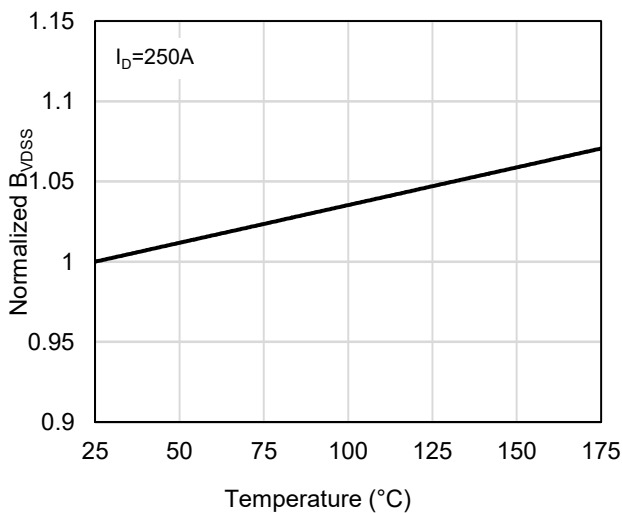

Figure 5: Breakdown Voltage vs. Junction Temperature

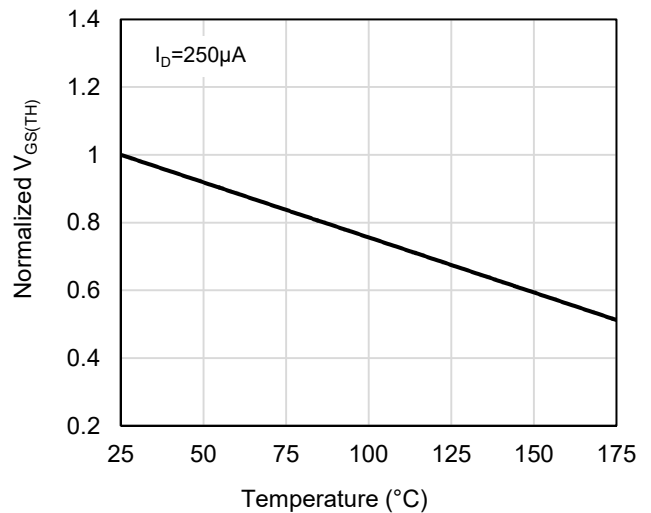
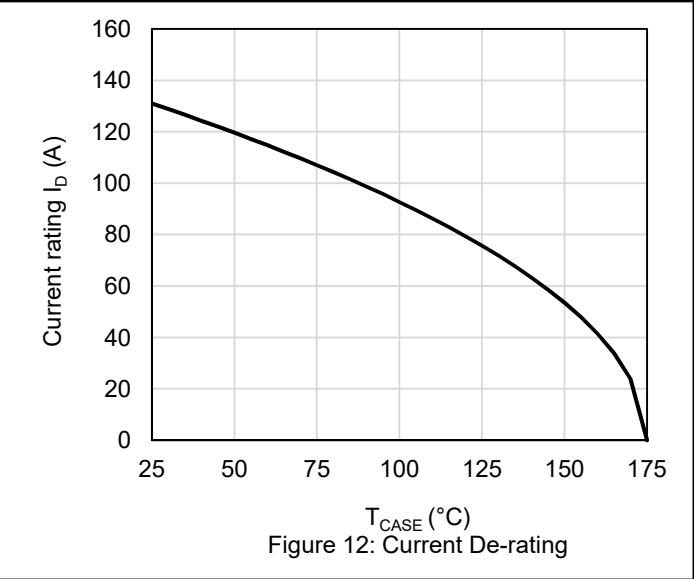
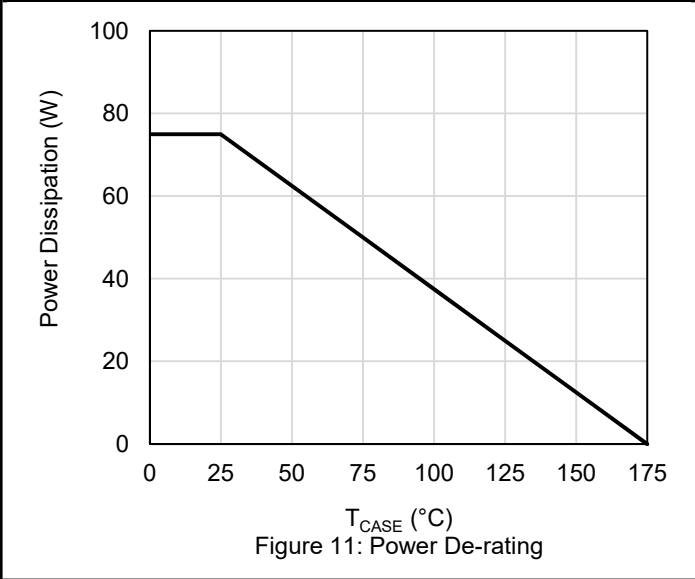
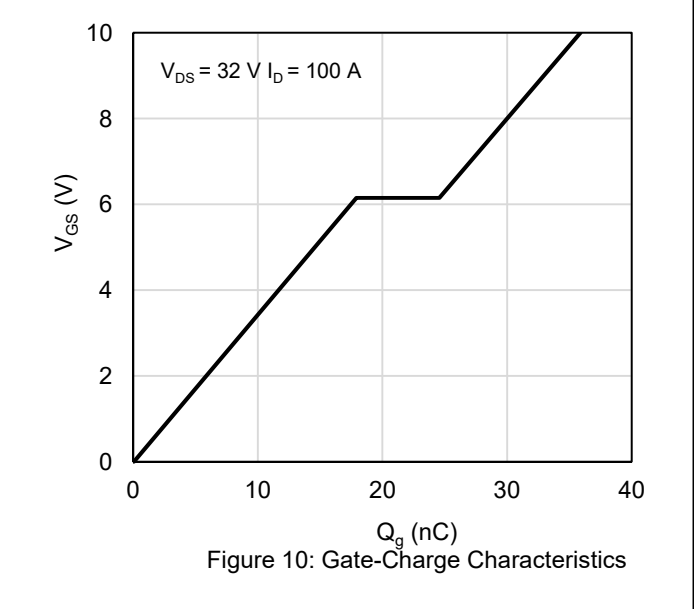
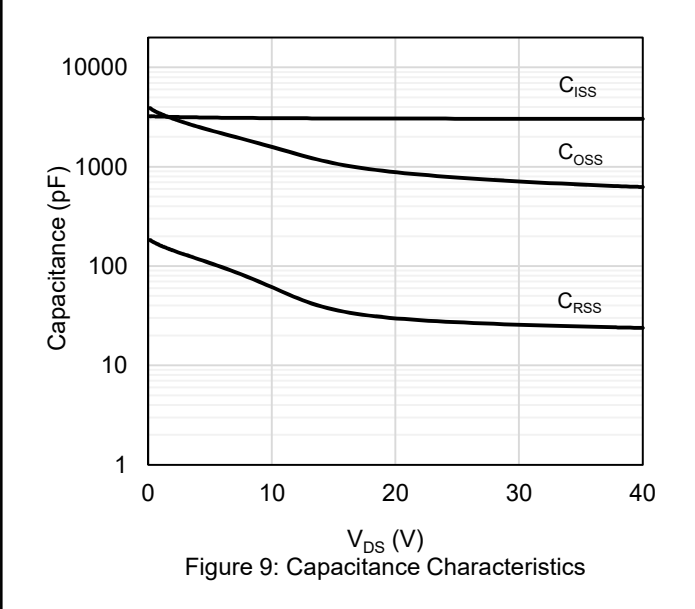
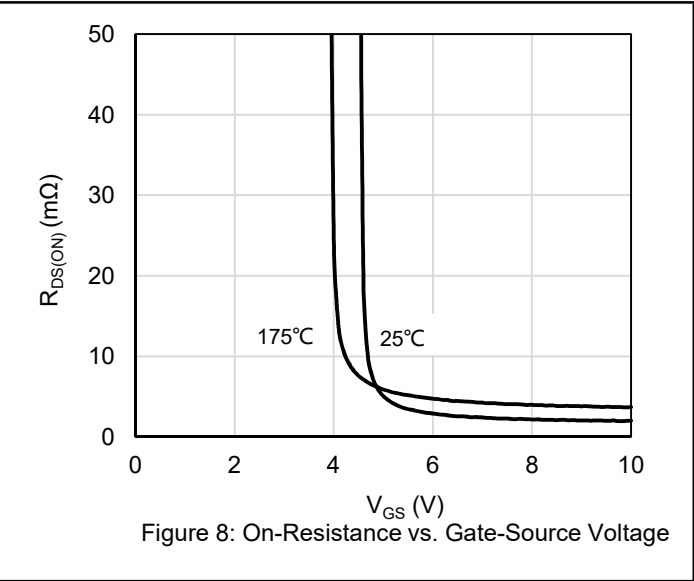
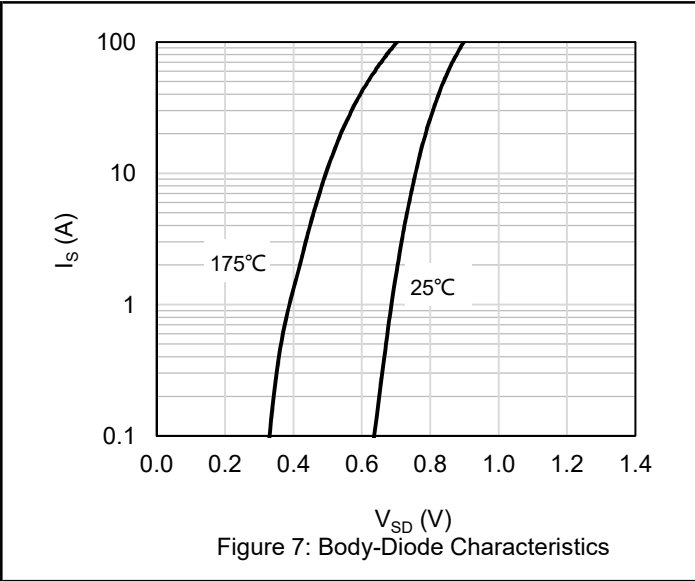

Figure 6: Threshold Voltage vs. Junction Temperature



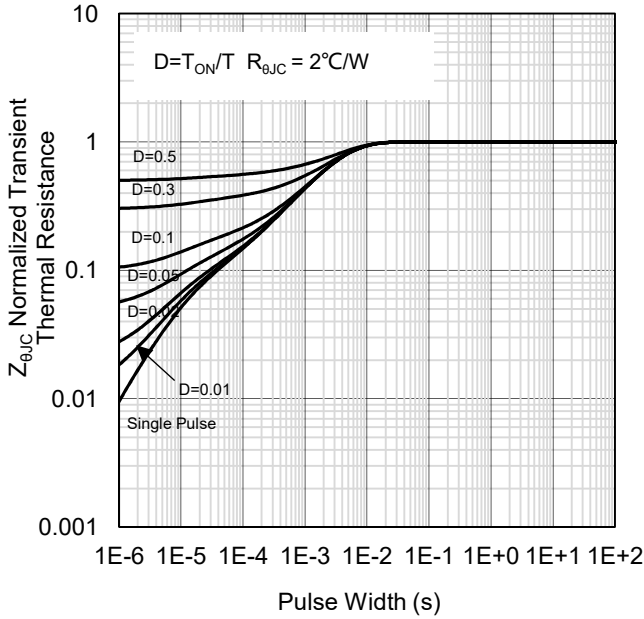

Figure 13: Normalized Maximum Transient Thermal Impedance

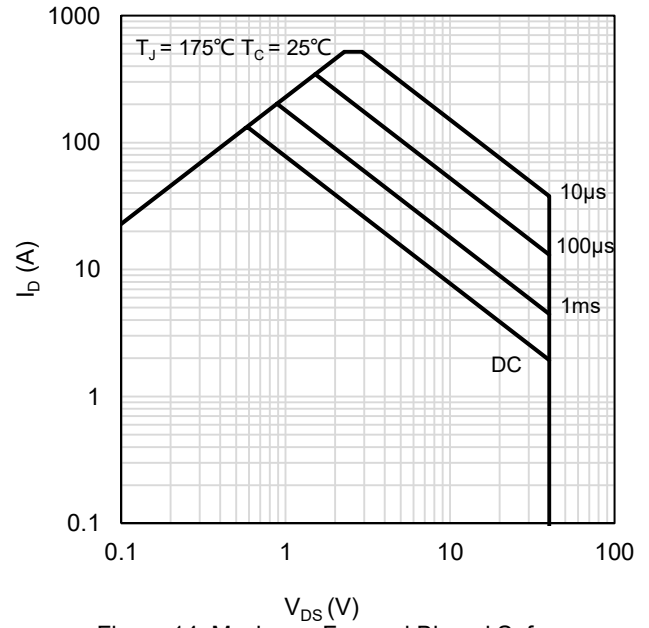
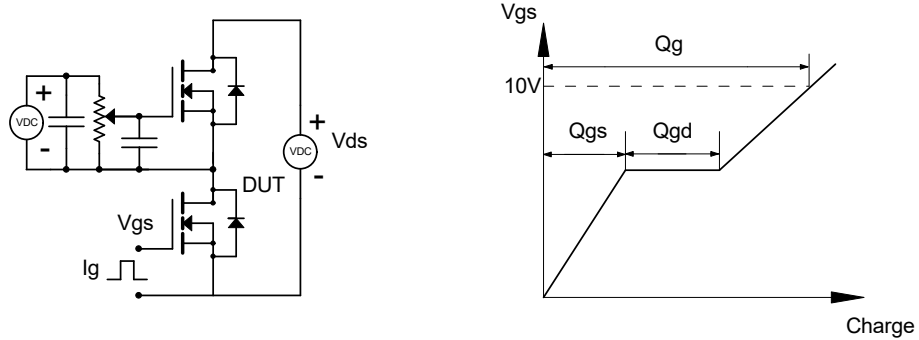

Figure 14: Maximum Forward Biased Safe Operating Area

Test Circuit and Waveform

Gate Charge Test Circuit & Waveform



Resistive Switching Test Circuit & Waveforms

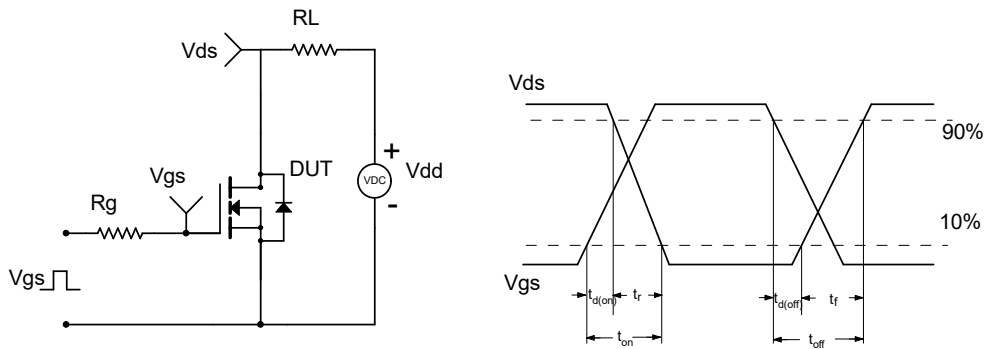

Unclamped Inductive Switching (UIS) Test Circuit & Waveforms

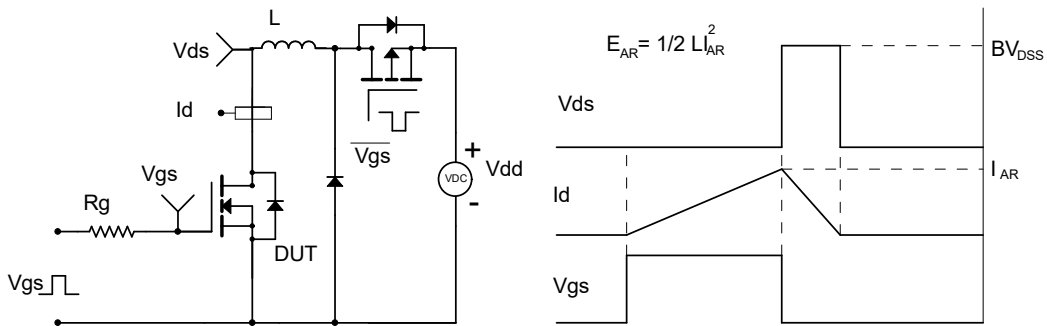

Diode Recovery Test Circuit & Waveforms

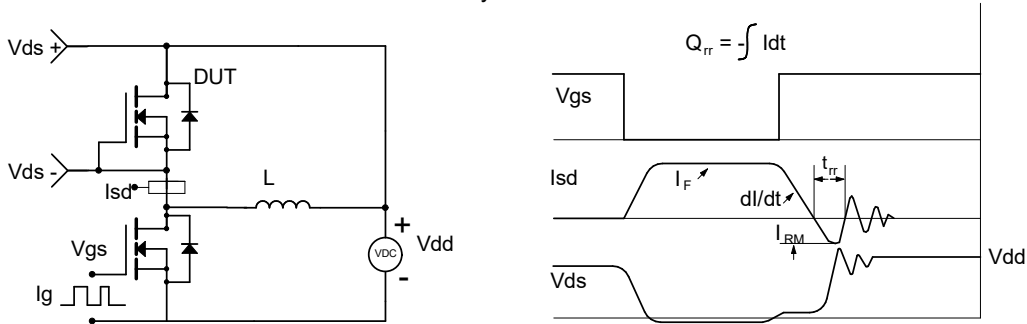

Package Outlines

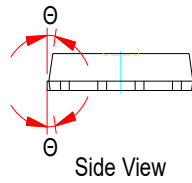
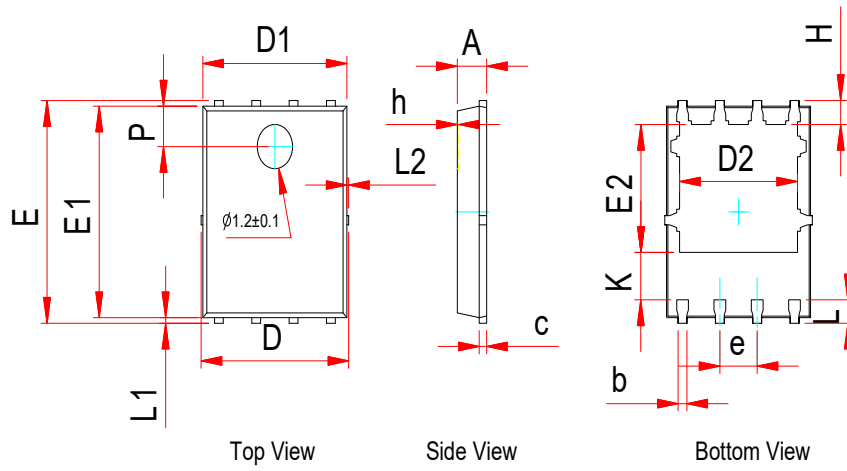

SYMBOL	MIN	NOM	MAX
A	0.90	1.00	1.10
b	0.20	0.30	0.40
c	0.21	0.25	0.34
D	-	-	5.10
D1	4.80	4.90	5.00
D2	3.91	4.01	4.11
e	1.27 BSC		
E	5.90	6.00	6.10
E1	5.65	5.75	5.85
E2	3.375	3.475	3.575
H	0.55	0.65	0.75
h	-	-	0.10
K	1.20	-	-
L	0.55	0.65	0.75
L1	0.05	0.15	0.25
L2	-	-	0.12
θ	8°	10°	12°
p	1.00	1.10	1.20

Unit in mm

Marking Information

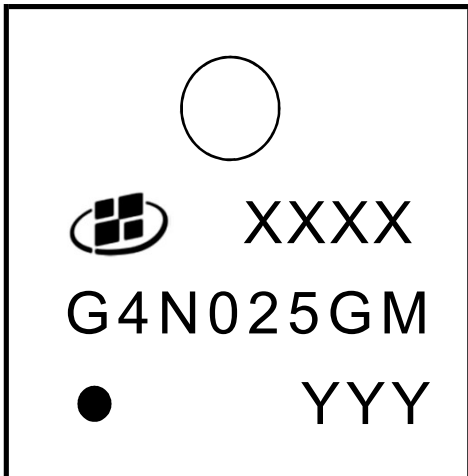

Note:
 G4N025GM = Product Name Code
 XXXX = Date code
 YYY
 Contact ALKAIDSEMI sales for detail information

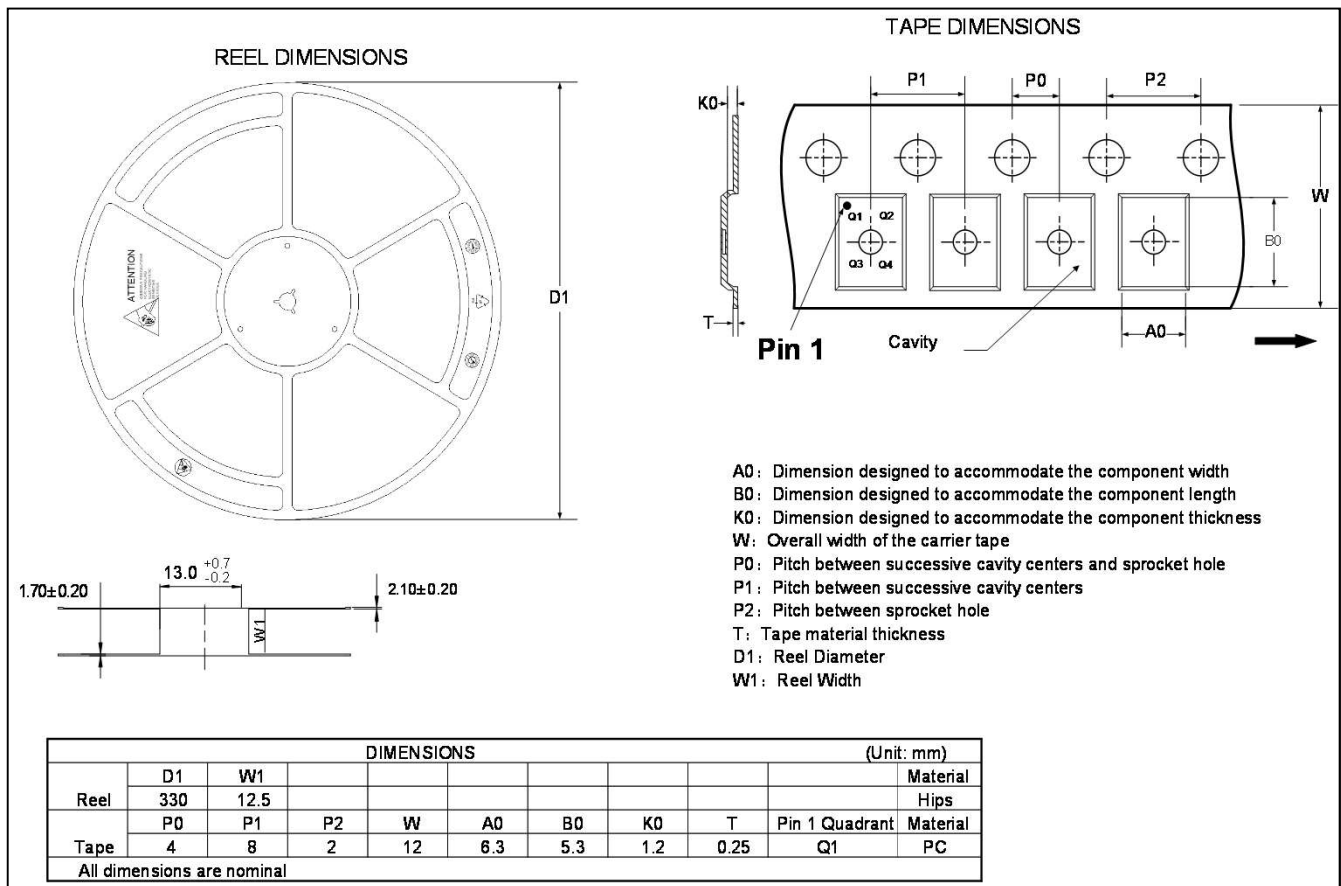

Revision History

Revision	Release Date	Remark
Rev.1.0	2022/12/7	Initial Release

Disclaimer

The information given in this document describes the independent performance of the product, but similar performance is not guaranteed under other working conditions, and cannot be guaranteed when installed with other products or equipment. To achieve the required performance of the product in actual scenarios, the customer should conduct a complete application test to assess the functionality of the product.

Alkaidsemi assumes no responsibility for equipment failures result from using products at values that exceed the ratings, operating conditions, or other parameters listed in the product specifications.

The product described in this specification is not applicable for aerospace or other applications which requires high reliability. Customers using or selling these products for use in medical, life-saving, or life-sustaining applications do so at their own risk and agree to fully indemnify.

Due to product or technical improvements, the information described or contained herein may be changed without prior notice.