

100V 2mohm N-channel SGT MOSFET

AKG10N020TM-A

Description:

This device is designed for automotive applications and manufactured in IATF16949 certified facilities. Qualified AEC-Q101, PPAP capable.

Features:

- Low $R_{DS(ON)}$
- RoHS compliant ^(Note 1)
- Halogen-free ^(Note 1)
- 100% UIS tested
- AEC-Q101 qualified and PPAP capable
- Wettable Flank for Improved Optical Inspection

Applications:

- Battery Management System
- Motor Drivers

Key Performance Parameters:

Parameter	Value	Unit
V_{DS}	100	V
$R_{DS(ON), max} @ V_{GS} = 10 V$	2	m Ω
I_D	300	A

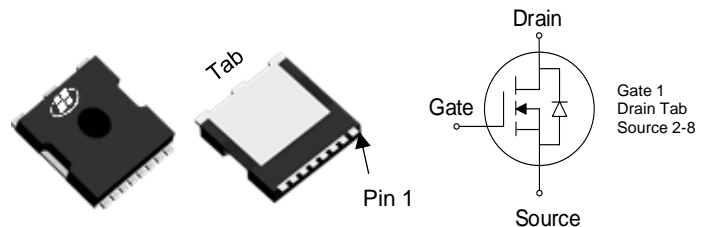

Ordering Information:

Ordering Code	Package Type	Marking Code	Form	Packing
AKG10N020TM-A	TOLL	G10N020TM	Tape Reel	2000PCS

Notes:

1. Contact ALKAIDSEMI sales for detail information

Maximum Ratings (T_A = 25°C unless otherwise noted)

Symbol	Parameter	Value	Units
V _{DS}	Drain-Source Voltage	100	V
I _D	Drain Current - Continuous (T _C = 25°C) ^(Note 1)	300	A
	Drain Current - Continuous (T _C = 100°C)	211	A
I _{DM}	Drain Current - Pulsed ^(Note 2)	1200	A
V _{GS}	Gate-Source Voltage	± 20	V
E _{AS}	Single Pulsed Avalanche Energy ^(Note 3)	702	mJ
P _D	Power Dissipation (T _C = 25°C)	375	W
T _J , T _{STG}	Operating and Storage Temperature Range	-55 to +175	°C

Thermal Characteristics

Symbol	Parameter	Value	Units
R _{θJC}	Thermal Resistance, Junction-to-Case, Steady-State	0.4	°C/W
R _{θJA}	Thermal Resistance, Junction-to-Ambient, Steady State ^(Note 4)	45	°C/W

Notes:

1. The max drain current rating is package limited
2. Repetitive Rating: Pulse width limited by maximum junction temperature
3. L = 0.5 mH, V_{DD} = 50 V, I_{AS} = 53 A, R_g = 50 Ω, Starting T_J = 25 °C
4. Mount on minimum PCB layout

Electrical Characteristics ($T_J = 25^\circ\text{C}$ unless otherwise noted)						
Symbol	Parameter	Test Conditions	Min	Typ	Max	Units
Static Characteristics						
$V_{(BR)DSS}$	Drain-Source Breakdown Voltage	$V_{GS} = 0\text{ V}, I_D = 250\ \mu\text{A}$	100			V
I_{DSS}	Zero Gate Voltage Drain Current	$V_{DS} = 100\text{ V}, V_{GS} = 0\text{ V},$			1	μA
I_{GSS}	Gate Leakage Current	$V_{GS} = \pm 20\text{ V}, V_{DS} = 0\text{ V}$			± 100	nA
$V_{GS(th)}$	Gate Threshold voltage	$V_{DS} = V_{GS}, I_D = 250\ \mu\text{A}$	2	2.9	4	V
$R_{DS(ON)}$	Drain-Source on-state resistance	$V_{GS} = 10\text{ V}, I_D = 20\text{ A}$		1.5	2	m Ω
Dynamic Characteristics						
C_{iss}	Input Capacitance	$V_{DS} = 50\text{ V}, V_{GS} = 0\text{ V},$ $f = 1\text{ MHz}$		9325		pF
C_{oss}	Output Capacitance			3065		pF
C_{rss}	Reverse Transfer Capacitance			105		pF
R_g	Gate Resistance	$f = 1\text{ MHz}$		1.8		Ω
Switching Characteristics						
$t_{D(on)}$	Turn On Delay Time	$V_{DD} = 50\text{ V}, R_L = 1\ \Omega,$ $V_{GS} = 10\text{ V}, R_G = 2.2\ \Omega$		33		ns
t_r	Rise Time			60		ns
$t_{D(off)}$	Turn Off Delay Time			70		ns
t_f	Fall Time			55		ns
Q_g	Total Gate Charge	$V_{DD} = 50\text{ V}, I_D = 50\text{ A},$ $V_{GS} = 10\text{ V}$		147		nC
Q_{gs}	Gate-Source Charge			42		nC
Q_{gd}	Gate-Drain Charge			39		nC
Drain-Source Diode Characteristics and Maximum Ratings						
I_S	Maximum Continuous Body-Diode Forward Current				300	A
I_{SM}	Maximum Pulsed Body-Diode Forward Current ^(NOTE 1)				1200	A
V_{SD}	Diode Forward Voltage	$V_{GS} = 0\text{ V}, I_S = 1\text{ A}$		0.66		V
t_{rr}	Reverse recovery time	$V_{DD} = 50\text{ V}, I_D = 50\text{ A},$ $di/dt = 100\text{ A}/\mu\text{S}$		85		ns
Q_{rr}	Reverse recovery charge			169		nC
I_{rrm}	Peak Reverse Recovery Current			3.5		A

Electrical Characteristics Diagrams

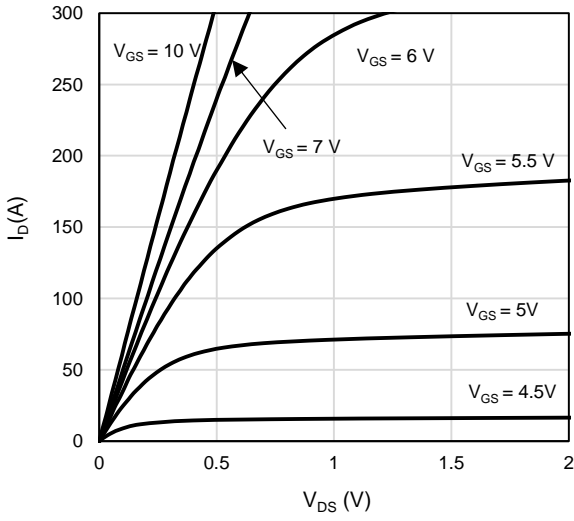

Figure 1: On-Region Characteristics

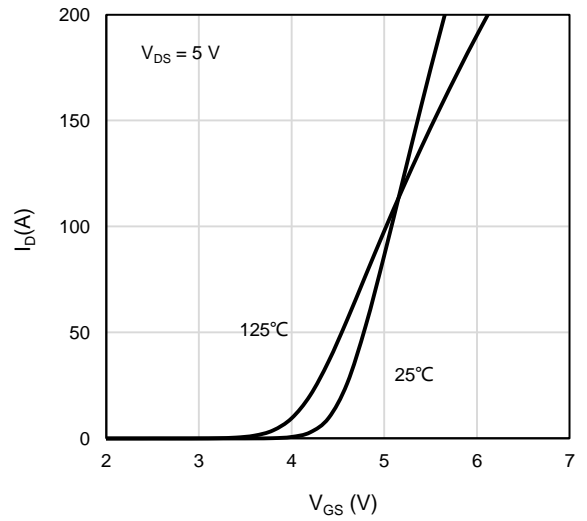

Figure 2: Transfer Characteristics

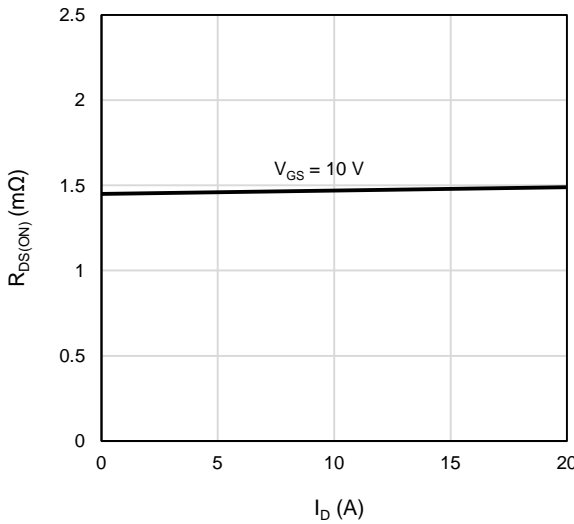

Figure 3: On-Resistance vs. Drain Current and Gate Voltage

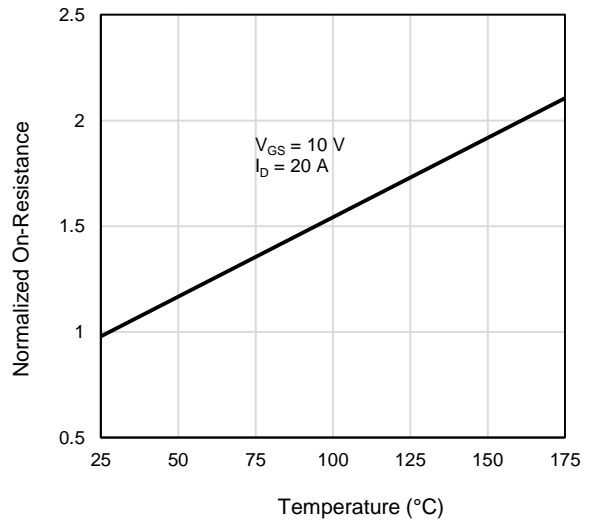

Figure 4: On-Resistance vs. Junction Temperature

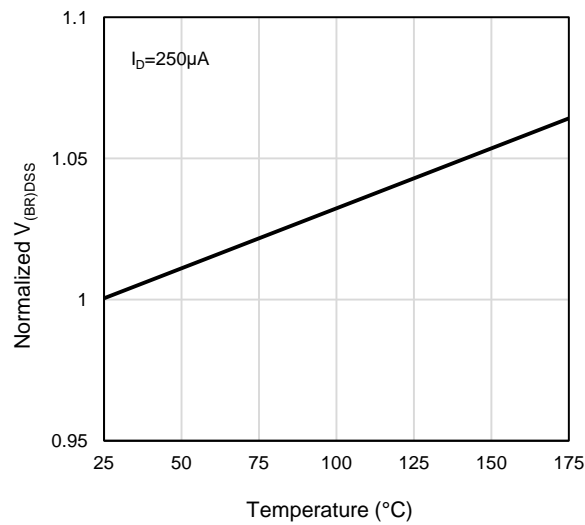

Figure 5: Breakdown Voltage vs. Junction Temperature

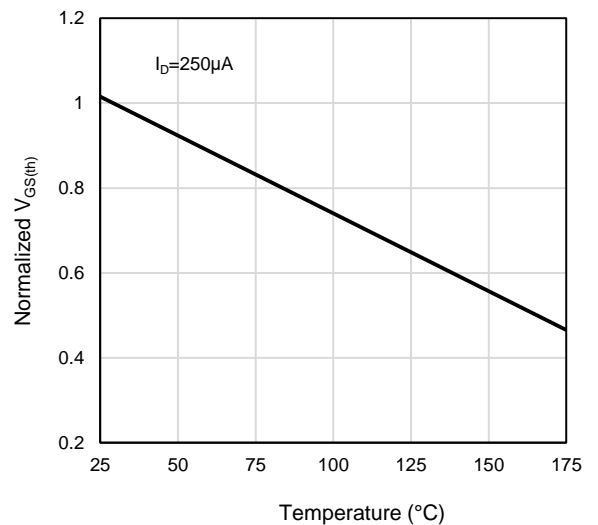

Figure 6: Threshold Voltage vs. Junction Temperature

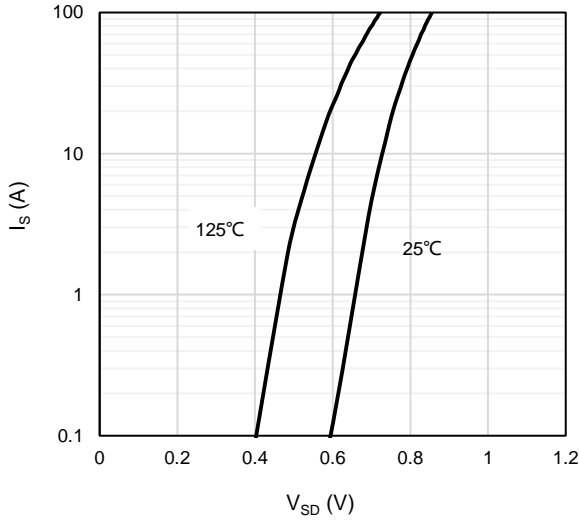

Figure 7: Body-Diode Characteristics

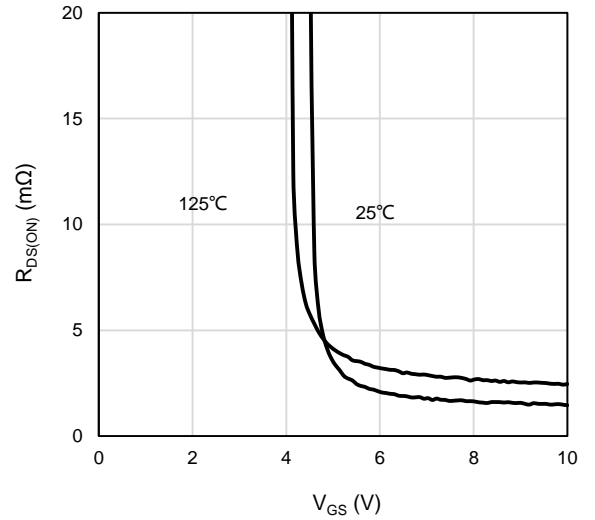

Figure 8: On-Resistance vs. Gate-Source Voltage

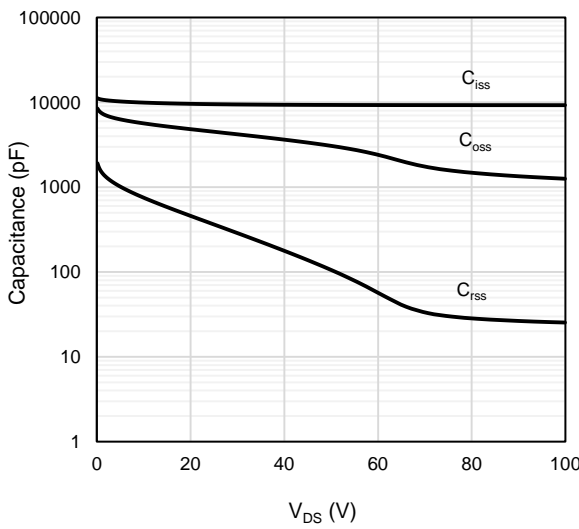

Figure 9: Capacitance Characteristics

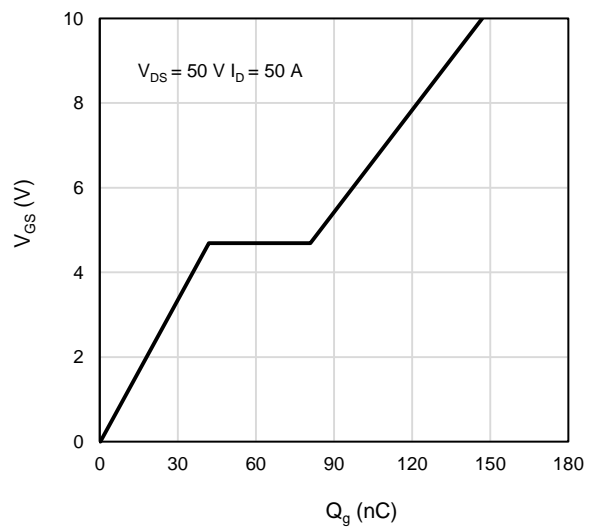

Figure 10: Gate-Charge Characteristics

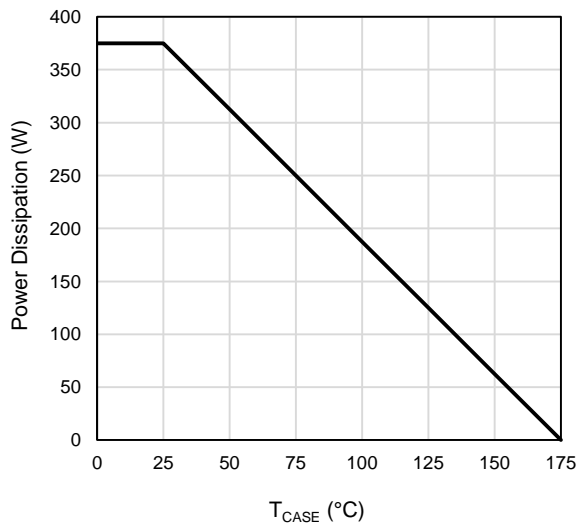

Figure 11: Power De-rating

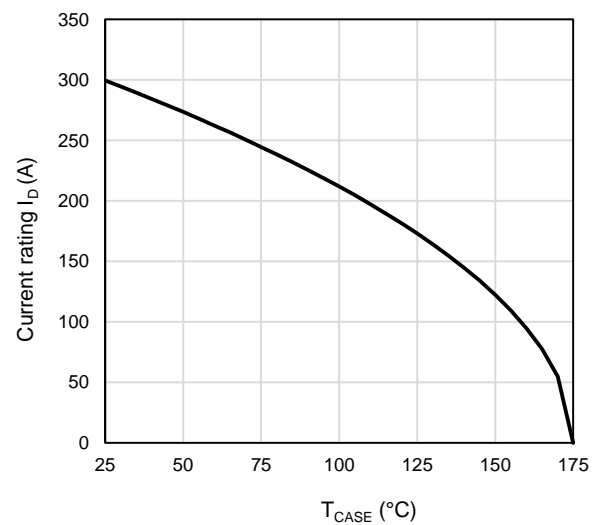

Figure 12: Current De-rating

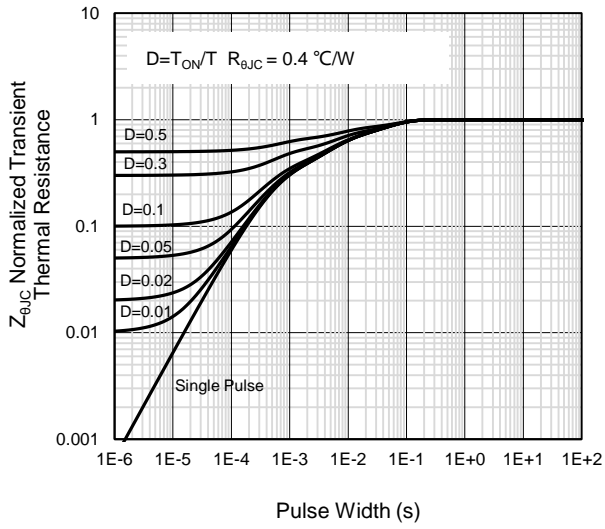

Figure 13: Normalized Maximum Transient Thermal Impedance

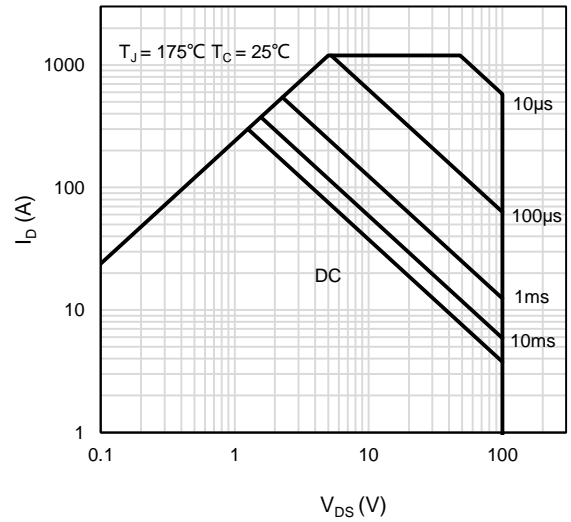
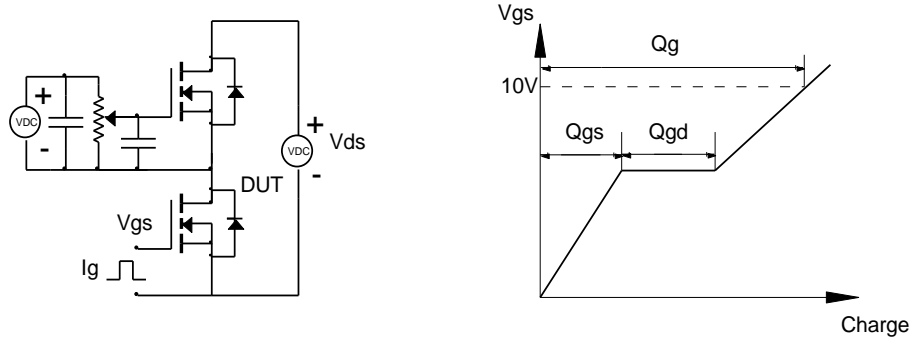

Figure 14: Maximum Forward Biased Safe Operating Area

Test Circuit and Waveform

Gate Charge Test Circuit & Waveform



Resistive Switching Test Circuit & Waveforms

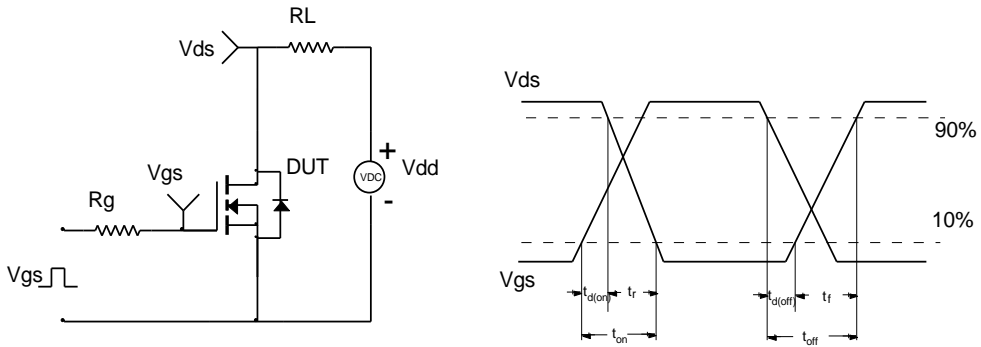

Unclamped Inductive Switching (UIS) Test Circuit & Waveforms

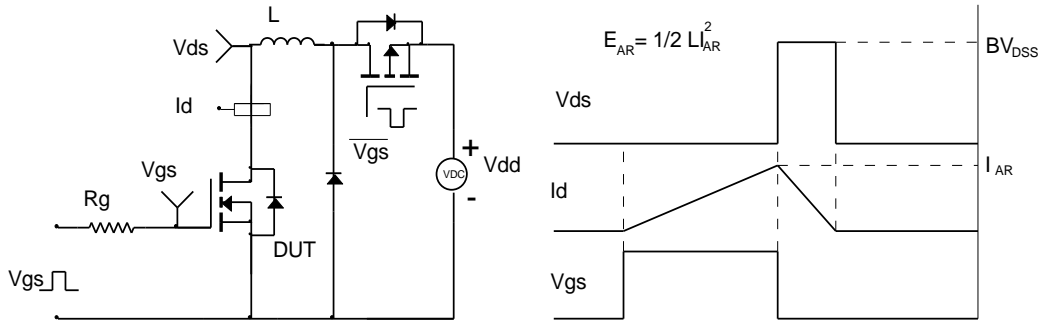

Diode Recovery Test Circuit & Waveforms

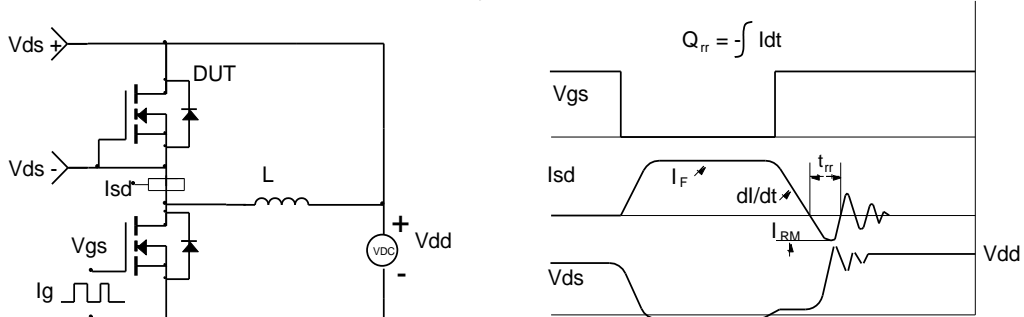

Package Outlines

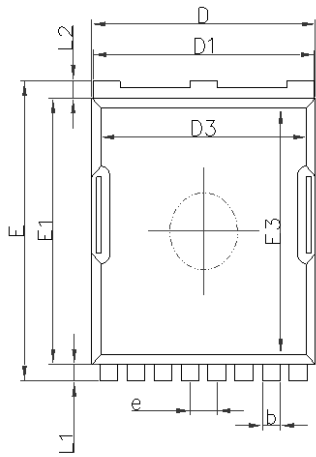

TOP VIEW

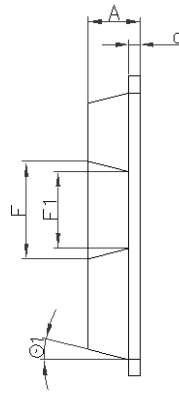

SIDE VIEW

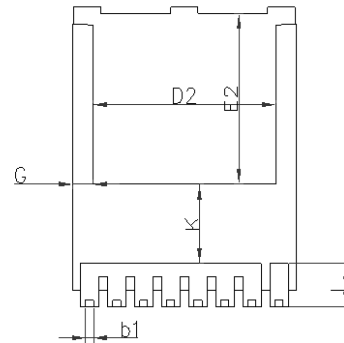

BTM VIEW

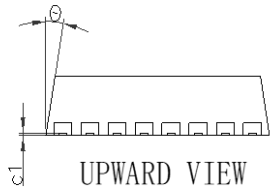

UPWARD VIEW

SYMBOL	MIN	NOM	MAX
A	2.20	2.30	2.40
b	0.75	0.80	0.85
b1	0.30	0.35	0.40
c	0.45	0.50	0.55
c1	0.05	0.10	0.15
D	9.80	9.90	10.00
D1	9.70	9.80	9.90
D2	8.00	8.10	8.30
D3	9.10 TYP.		
e	1.20 BSC		
E	11.60	11.70	11.80
E1	10.30	10.40	10.50
E2	6.55	6.65	6.75
E3	9.60 TYP.		
F	3.80 TYP.		
F1	3.00 TYP.		
G	0.80	0.90	1.00
K	3.00	3.10	3.20
L	1.59	1.69	1.79
L1	0.54	0.64	0.74
L2	0.56	0.66	0.76
θ	8°	10°	12°
θ1	10°	12°	14°

(UNITS OF MEASURE = MILLIMETER)

Marking Information



Note:

G10N020TM = Product Name Code

XXXXXXX = Date code

Contact ALKAIDSEMI sales for detail information

Tape & Reel Information

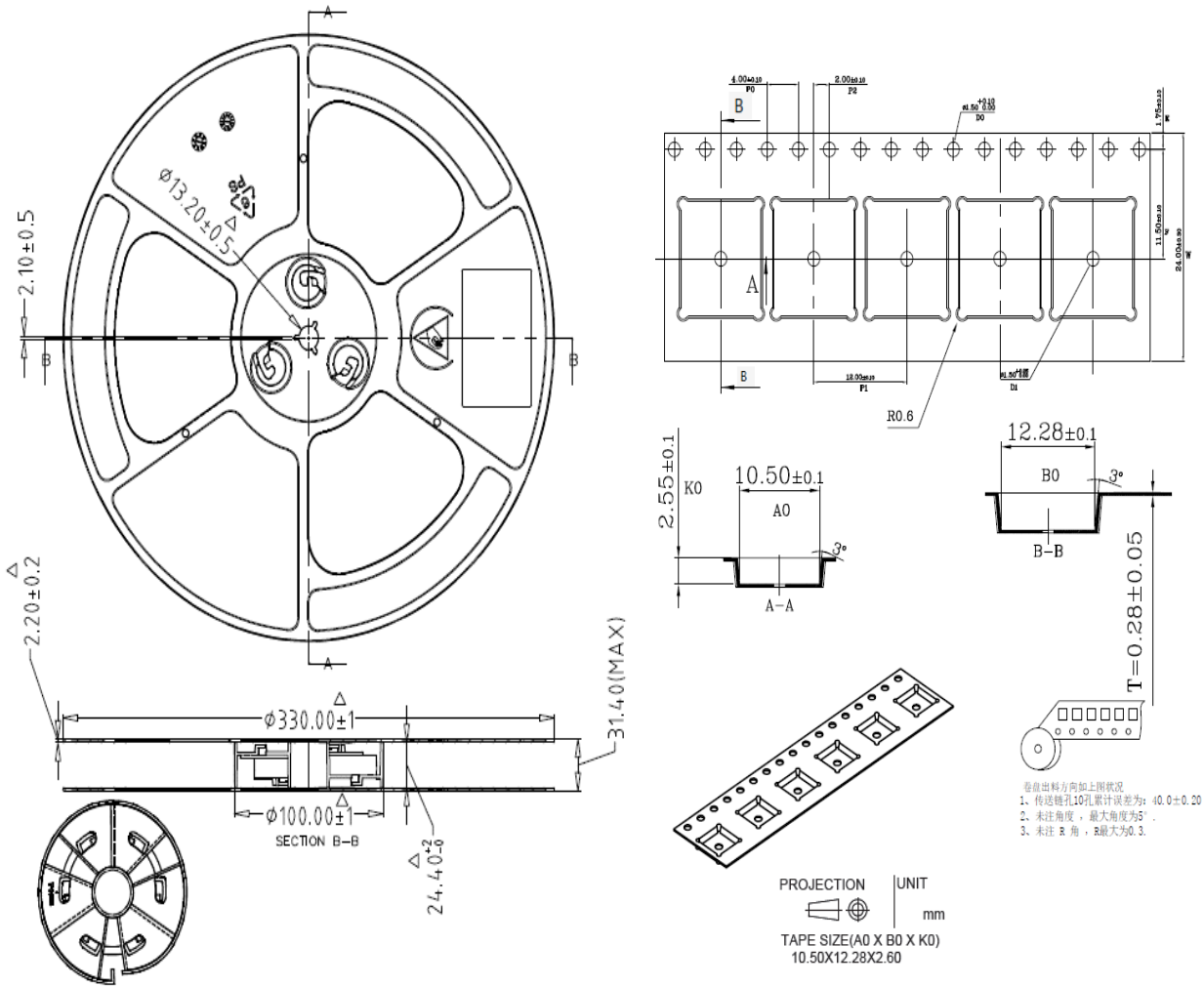

Revision History

Revision	Released	Remark
Rev.1.0	2023	Initial Release

Disclaimer

The information given in this document describes the independent performance of the product, but similar performance is not guaranteed under other working conditions, and cannot be guaranteed when installed with other products or equipment. To achieve the required performance of the product in actual scenarios, the customer should conduct a complete application test to assess the functionality of the product.

Alkaidsemi assumes no responsibility for equipment failures result from using products at values that exceed the ratings, operating conditions, or other parameters listed in the product specifications.

The product described in this specification is not applicable for aerospace or other applications which requires high reliability. Customers using or selling these products for use in medical, life-saving, or life-sustaining applications do so at their own risk and agree to fully indemnify.

Due to product or technical improvements, the information described or contained herein may be changed without prior notice.