

30V 0.7mohm N-channel SGT MOSFET AKG3N007GAL

Description:

This N channel SGT MOSFET has been designed for automotive applications and manufactured in IATF16949 certified facilities.

Features:

- Low $R_{DS(ON)}$
- RoHS compliant
- Halogen-free

Applications:

- Battery Management System
- Motor Drivers
- DC-DC Converter

Key Performance Parameters:

Parameter	Value	Unit
V_{DS}	30	V
$R_{DS(ON), max} @ V_{GS} = 10 V$	0.7	m Ω
I_D	288	A

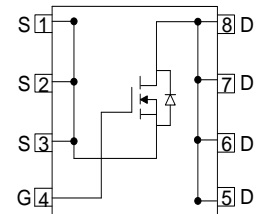
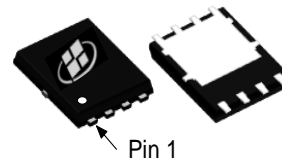

Ordering Information:

Ordering Code	Package Type	Marking Code	Form	Packing
AKG3N007GAL	PDFN5X6	G3N007GAL	Tape Reel	5000 per reel

Maximum Ratings ($T_A = 25^\circ\text{C}$ unless otherwise noted)

Symbol	Parameter	Value	Units
V_{DS}	Drain - Source Voltage	30	V
I_D	Drain Current - Continuous ($T_C = 25^\circ\text{C}$) ^(Note 1)	288	A
	Drain Current - Continuous ($T_C = 100^\circ\text{C}$)	182	A
I_{DM}	Drain Current - Pulsed ^(Note 2)	880	A
V_{GS}	Gate - Source Voltage	± 20	V
E_{AS}	Single Pulsed Avalanche Energy ^(Note 3)	702	mJ
P_D	Power Dissipation ($T_C = 25^\circ\text{C}$)	96	W
T_J, T_{STG}	Operating and Storage Temperature Range	-55 to +150	$^\circ\text{C}$

Thermal Characteristics

Symbol	Parameter	Value	Units
$R_{\theta JC}$	Thermal Resistance, Junction - to - Case, Steady State	1.3	$^\circ\text{C/W}$
$R_{\theta JA}$	Thermal Resistance, Junction - to - Ambient, Steady State ^(Note 4)	45	$^\circ\text{C/W}$

Notes:

1. The max drain current rating is silicon limited
2. Repetitive Rating: Pulse width limited by maximum junction temperature
3. $L = 0.5 \text{ mH}$, $V_{DD} = 40 \text{ V}$, $I_{AS} = 53 \text{ A}$, $R_g = 50 \Omega$, Starting $T_J = 25^\circ\text{C}$
4. Mount on minimum PCB layout

Electrical Characteristics ($T_J = 25^\circ\text{C}$ unless otherwise noted)						
Symbol	Parameter	Test Conditions	Min	Typ	Max	Units
Static Characteristics						
$V_{(BR)DSS}$	Drain - Source Breakdown Voltage	$V_{GS} = 0\text{ V}, I_D = 1\text{ mA}$	30			V
I_{DSS}	Zero Gate Voltage Drain Current	$V_{DS} = 30\text{ V}, V_{GS} = 0\text{ V},$			1	μA
I_{GSS}	Gate Leakage Current	$V_{GS} = \pm 20\text{ V}, V_{DS} = 0\text{ V}$			± 100	nA
$V_{GS(th)}$	Gate Threshold voltage	$V_{DS} = V_{GS}, I_D = 250\ \mu\text{A}$	1	1.7	3	V
$R_{DS(ON)}$	Drain - Source on - state resistance	$V_{GS} = 10\text{ V}, I_D = 20\text{ A}$		0.55	0.7	$\text{m}\Omega$
		$V_{GS} = 4.5\text{ V}, I_D = 20\text{ A}$		0.8	1	$\text{m}\Omega$
Dynamic Characteristics						
C_{iss}	Input Capacitance	$V_{DS} = 15\text{ V}, V_{GS} = 0\text{ V},$ $f = 1\text{ MHz}$		8334		pF
C_{oss}	Output Capacitance			2849		pF
C_{rss}	Reverse Transfer Capacitance			648		pF
R_g	Gate Resistance	$f = 1\text{ MHz}$		2.5		Ω
Switching Characteristics						
$t_{d(on)}$	Turn On Delay Time	$V_{DD} = 15\text{ V}, R_L = 0.75\ \Omega,$ $V_{GS} = 10\text{ V}, R_G = 6.8\ \Omega$		13		ns
t_r	Rise Time			41		ns
$t_{d(off)}$	Turn Off Delay Time			85		ns
t_f	Fall Time			60		ns
Q_g	Total Gate Charge	$V_{DD} = 15\text{ V}, I_D = 20\text{ A},$ $V_{GS} = 10\text{ V}$		140		nC
Q_{gs}	Gate - Source Charge			24		nC
Q_{gd}	Gate - Drain Charge			34		nC
Drain - Source Diode Characteristics and Maximum Ratings						
I_S	Maximum Continuous Body - Diode Forward Current				288	A
I_{SM}	Maximum Pulsed Body - Diode Forward Current				880	A
V_{SD}	Diode Forward Voltage	$V_{GS} = 0\text{ V}, I_S = 1\text{ A}$		0.63		V
t_{rr}	Reverse recovery time	$V_{DD} = 15\text{ V}, I_D = 15\text{ A},$ $di/dt = 100\text{ A}/\mu\text{s}$		75		ns
Q_{rr}	Reverse recovery charge			95		nC
I_{rrm}	Peak Reverse Recovery Current			2.1		A

Electrical Characteristics Diagrams

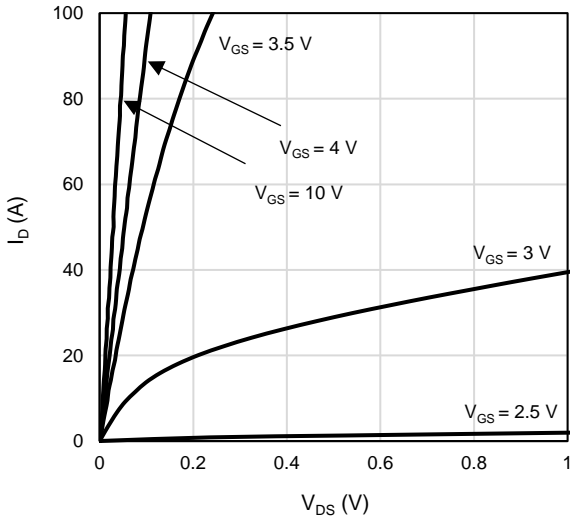

Figure 1: On-Region Characteristics

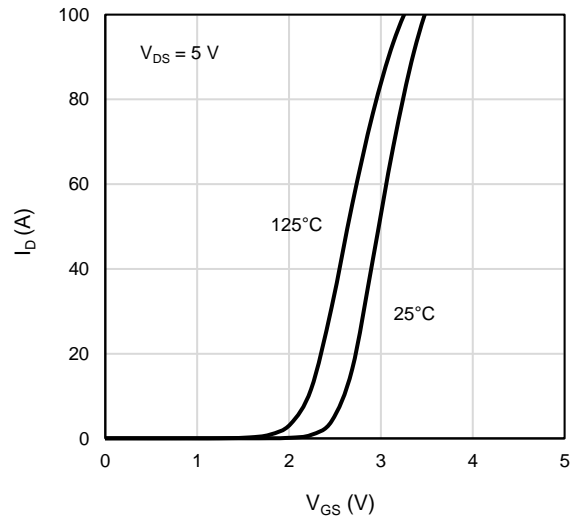

Figure 2: Transfer Characteristics

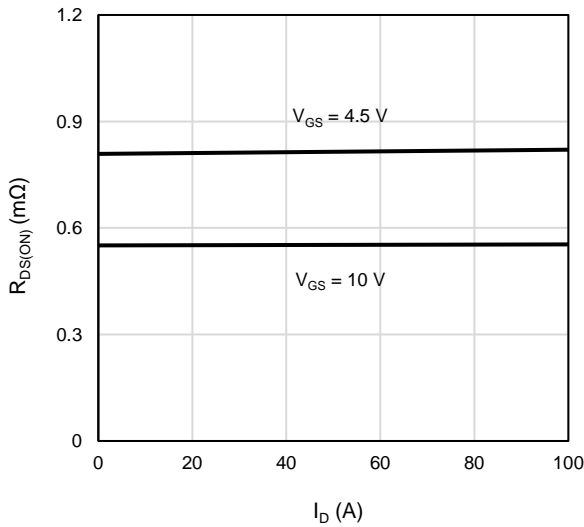

Figure 3: On-Resistance vs. Drain Current and Gate Voltage

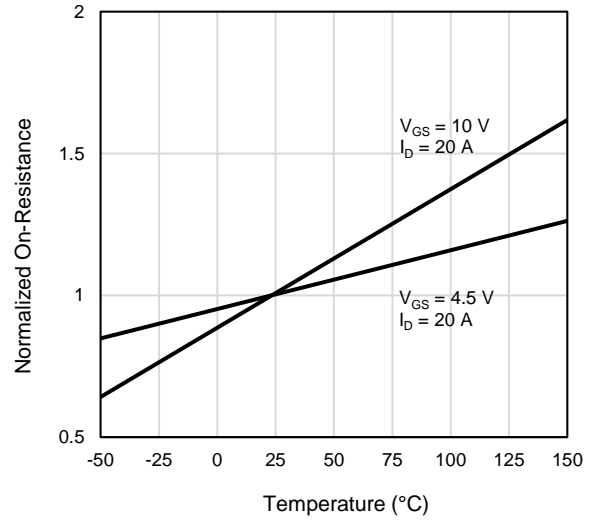

Figure 4: On-Resistance vs. Junction Temperature

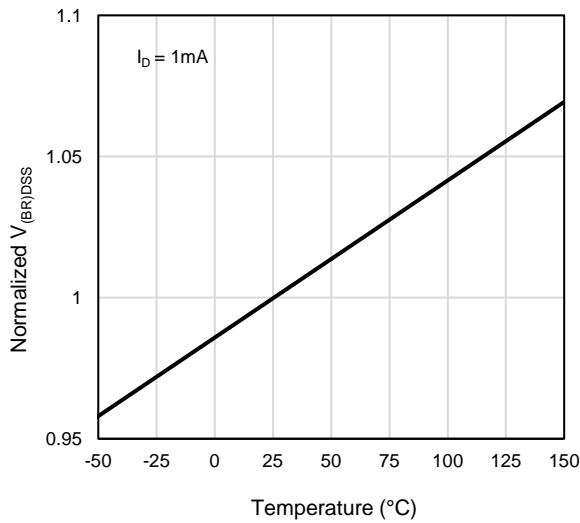

Figure 5: Breakdown Voltage vs. Junction Temperature

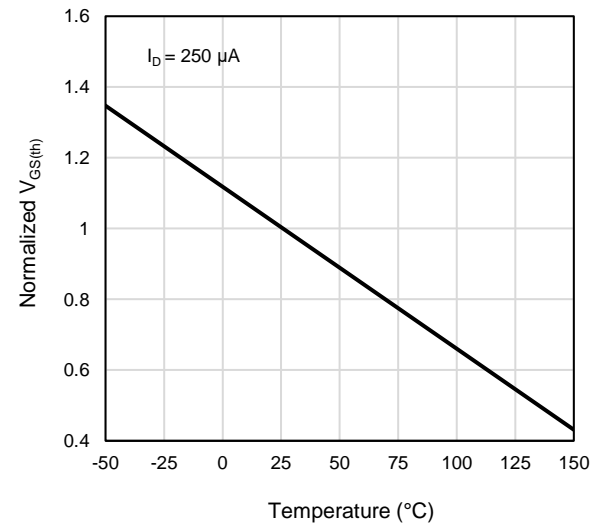

Figure 6: Threshold Voltage vs. Junction Temperature

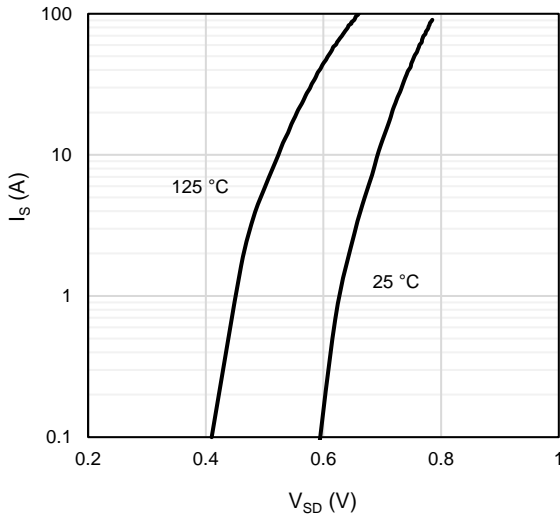

Figure 7: Body-Diode Characteristics

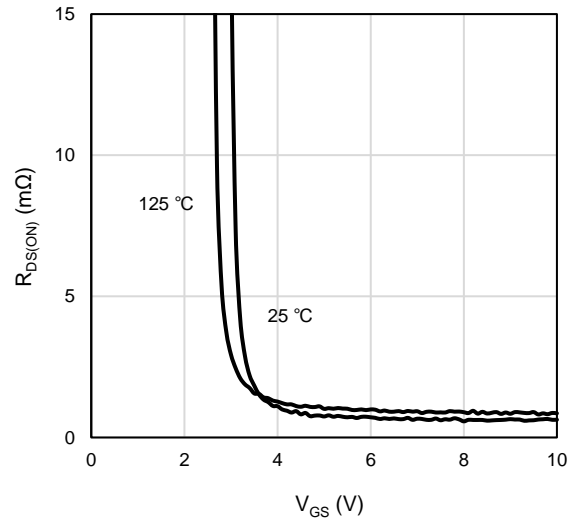

Figure 8: On-Resistance vs. Gate-Source Voltage

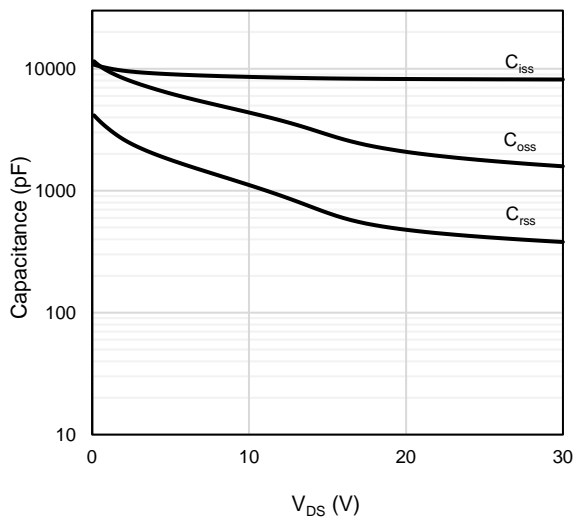

Figure 9: Capacitance Characteristics

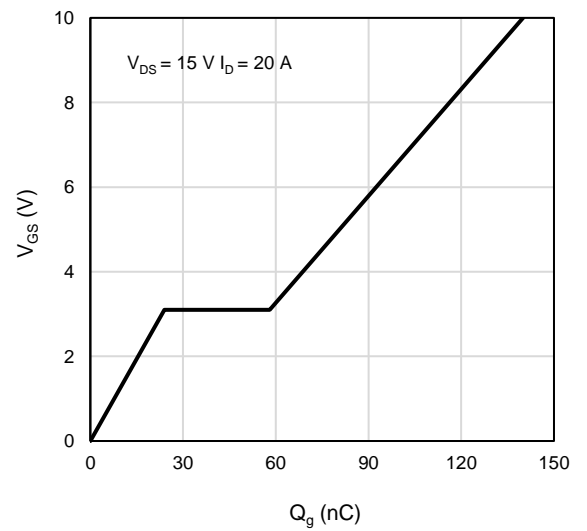

Figure 10: Gate-Charge Characteristics

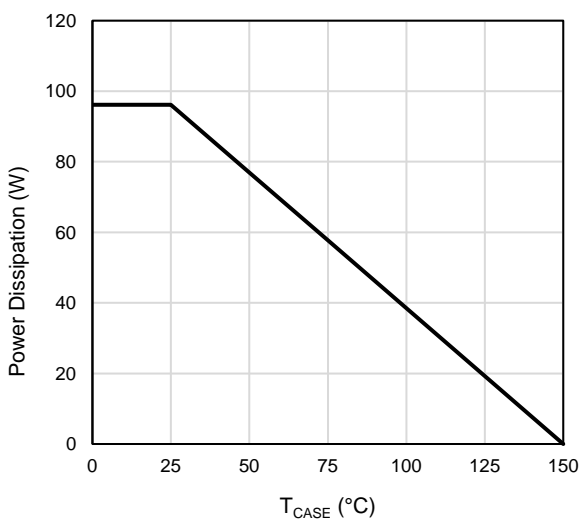

Figure 11: Power De-rating

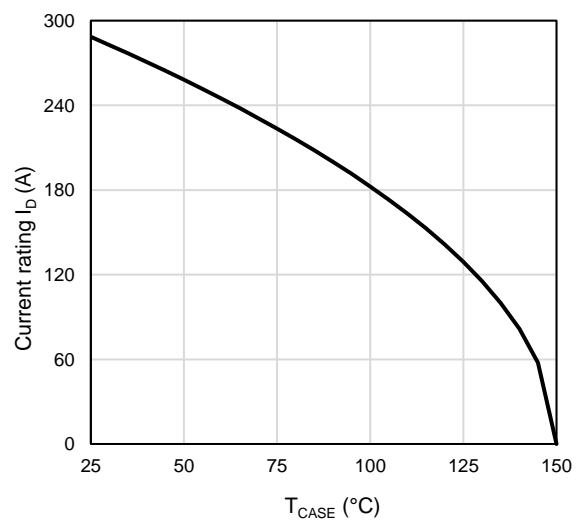

Figure 12: Current De-rating

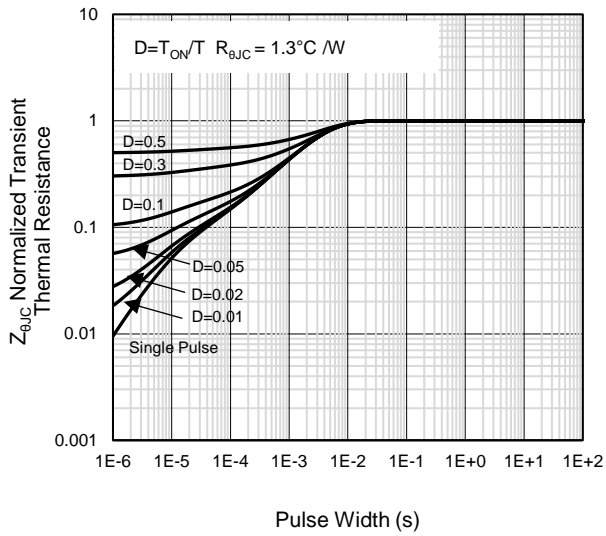

Figure 13: Normalized Maximum Transient Thermal Impedance

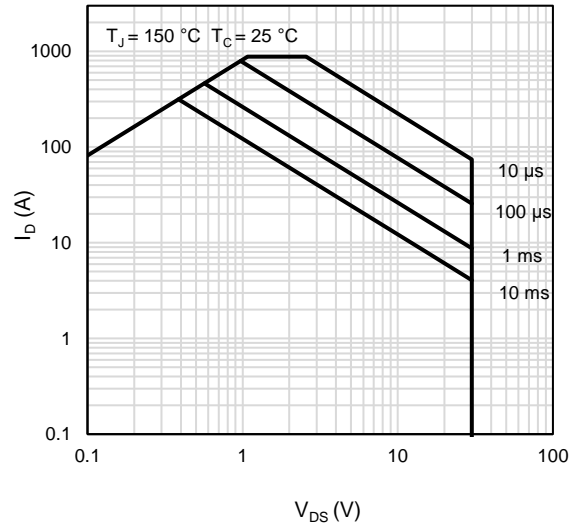
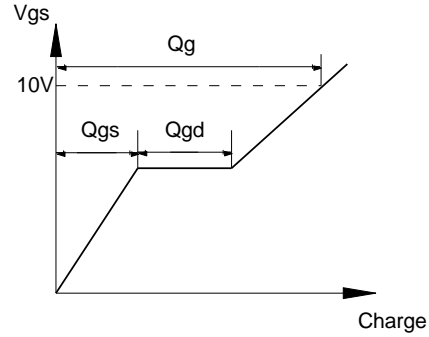
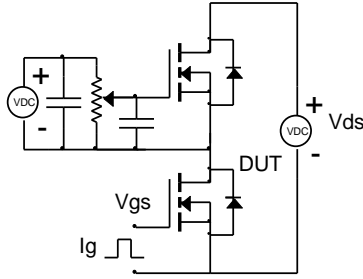

Figure 14: Maximum Forward Biased Safe Operating Area

Test Circuit and Waveform

Gate Charge Test Circuit & Waveform



Resistive Switching Test Circuit & Waveforms

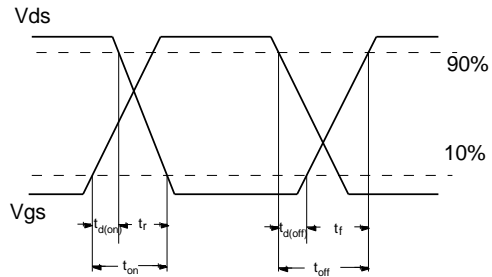
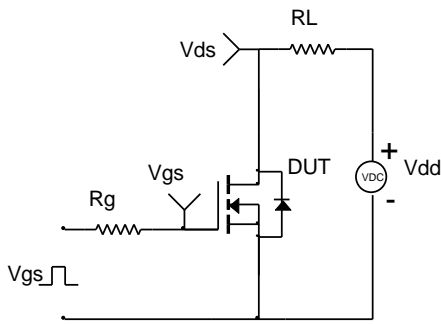

Unclamped Inductive Switching (UIS) Test Circuit & Waveforms

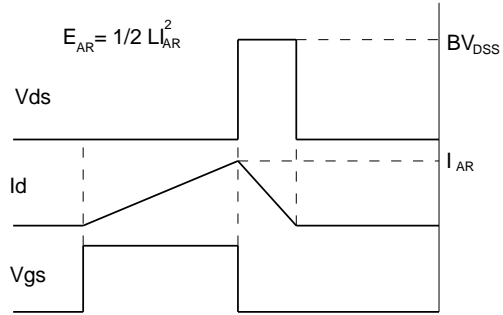
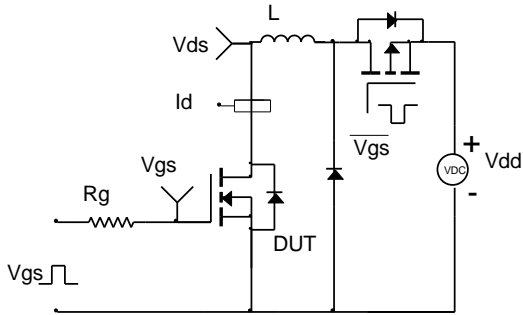

Diode Recovery Test Circuit & Waveforms

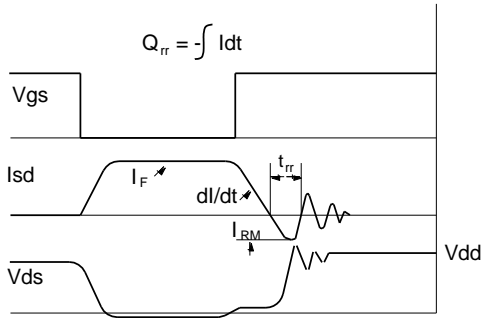
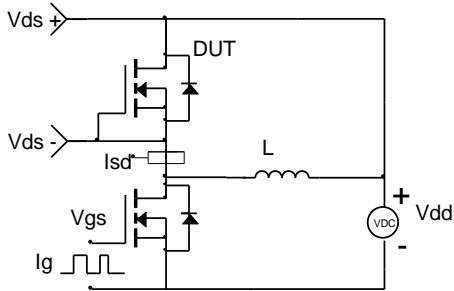

Package Outlines

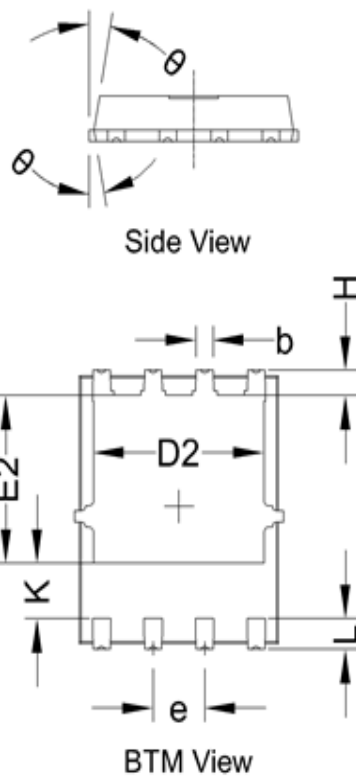
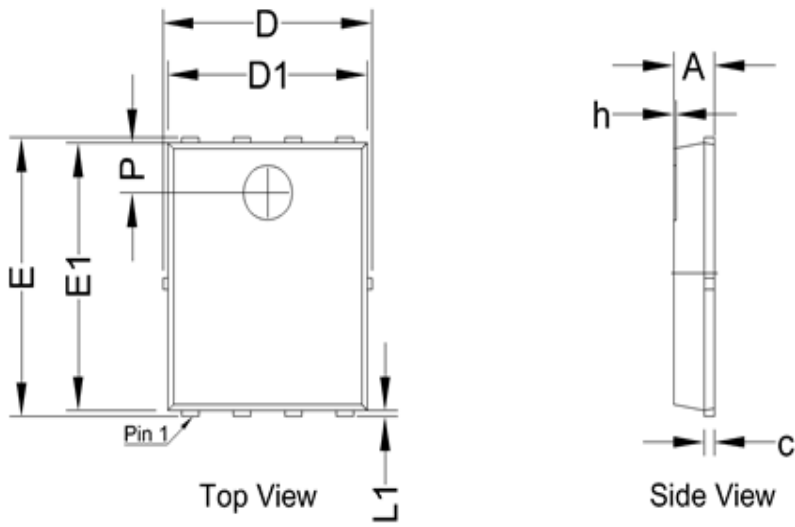

SYMBOL	MIN	NOM	MAX
A	0.90	1.00	1.10
b	0.32	0.42	0.52
c	0.21	0.25	0.34
D	5.00	5.15	5.30
D1	4.80	4.90	5.00
D2	4.10	4.20	4.30
e	1.27BSC		
E	6.00	6.15	6.30
E1	5.80	5.90	6.00
E2	3.60	3.70	3.80
H	0.45	0.55	0.65
h	-	-	0.10
K	1.17	-	-
L	0.58	0.68	0.78
L1	0.05	0.13	0.21
∅	8°	10°	12°
P	1.05	1.10	1.15

Unit in mm

Marking Information

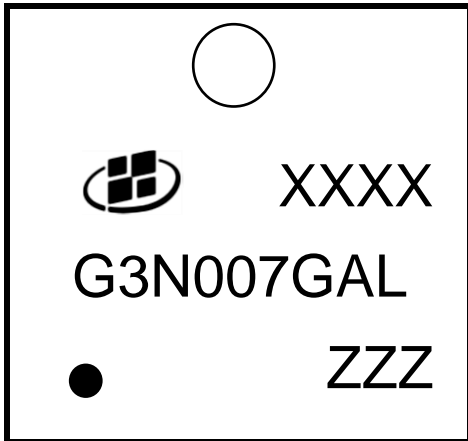

Note:

G3N007GAL = Product Name Code

XXXX = Date code

ZZZ

Contact ALKAIDSEMI sales for detail information

Tape & Reel Information

REEL DIMENSIONS

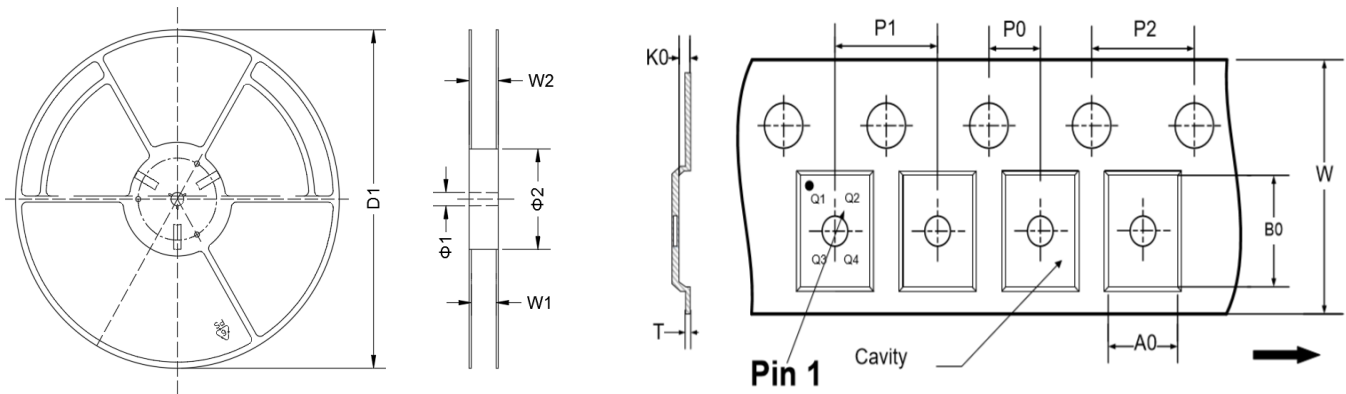

DIMENSIONS(Unit:mm)										
Tape	P0	P1	P2	W	A0	B0	K0	T	Pin1 Quadrant	Material
	2	8	4	12	6.45	5.45	1.2	0.25	Q2	PC
DIMENSIONS(Unit:mm)										
Reel	D1	W1	W2	Φ1	Φ2					Material
	330	12.4	18.4	13.5	100					Hips

Revision History

Revision	Released	Remark
Rev.1.0	2024	Initial Release

Disclaimer

The information given in this document describes the independent performance of the product, but similar performance is not guaranteed under other working conditions, and cannot be guaranteed when installed with other products or equipment. To achieve the required performance of the product in actual scenarios, the customer should conduct a complete application test to assess the functionality of the product.

Alkaidsemi assumes no responsibility for equipment failures result from using products at values that exceed the ratings, operating conditions, or other parameters listed in the product specifications.

The product described in this specification is not applicable for aerospace or other applications which requires high reliability. Customers using or selling these products for use in medical, life-saving, or life-sustaining applications do so at their own risk and agree to fully indemnify.

Due to product or technical improvements, the information described or contained herein may be changed without prior notice.