

## 30V 0.5mohm N-channel SGT MOSFET AKG3N005GAL

### Description:

This N channel SGT MOSFET has been designed to ultra low on-state resistance and maintain superior switching performance, especially for high efficiency power management applications.

### Features:

- Low  $R_{DS(ON)}$
- RoHS compliant
- Halogen-free

### Applications:

- Battery Management System
- Motor Drivers
- DC-DC Converter
- Power Load Switch

### Key Performance Parameters:

Parameter	Value	Unit
$V_{DS}$	30	V
$R_{DS(ON), max} @ V_{GS} = 10 V$	0.5	m $\Omega$
$I_D$	430	A

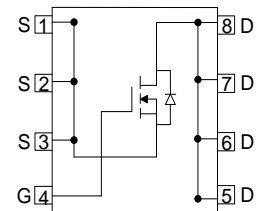
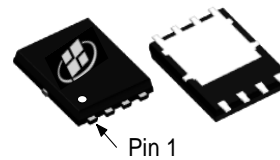

### Ordering Information:

Ordering Code	Package Type	Marking Code	Form	Packing
AKG3N005GAL	PDFN5X6	G3N005GAL	Tape Reel	5000 per reel

## Maximum Ratings (T<sub>A</sub> = 25°C unless otherwise noted)

Symbol	Parameter	Value	Units
V <sub>DS</sub>	Drain-Source Voltage	30	V
I <sub>D</sub>	Drain Current - Continuous (T <sub>C</sub> = 25°C) <sup>(Note 1)</sup>	430	A
	Drain Current - Continuous (T <sub>C</sub> = 100°C)	272	A
I <sub>DM</sub>	Drain Current - Pulsed <sup>(Note 2)</sup>	900	A
V <sub>GS</sub>	Gate-Source Voltage	± 20	V
E <sub>AS</sub>	Single Pulsed Avalanche Energy <sup>(Note 3)</sup>	238	mJ
P <sub>D</sub>	Power Dissipation (T <sub>C</sub> = 25°C)	138	W
T <sub>J</sub> , T <sub>STG</sub>	Operating and Storage Temperature Range	-55 to +150	°C

## Thermal Characteristics

Symbol	Parameter	Value	Units
R <sub>θJC</sub>	Thermal Resistance, Junction-to-Case, Steady-State	0.9	°C/W
R <sub>θJA</sub>	Thermal Resistance, Junction-to-Ambient, Steady State <sup>(Note 4)</sup>	45	°C/W

### Notes:

1. The max drain current rating is silicon limited
2. Repetitive Rating: Pulse width limited by maximum junction temperature
3. L = 0.1 mH, V<sub>DD</sub> = 30 V, I<sub>AS</sub> = 69 A, R<sub>g</sub> = 25 Ω, Starting T<sub>J</sub> = 25 °C
4. Mount on minimum PCB layout

Electrical Characteristics (T <sub>J</sub> = 25°C unless otherwise noted)						
Symbol	Parameter	Test Conditions	Min	Typ	Max	Units
<b>Static Characteristics</b>						
V <sub>(BR)DSS</sub>	Drain-Source Breakdown Voltage	V <sub>GS</sub> = 0 V, I <sub>D</sub> = 250 μA	30			V
I <sub>DSS</sub>	Zero Gate Voltage Drain Current	V <sub>DS</sub> = 30 V, V <sub>GS</sub> = 0 V,			1	μA
I <sub>GSS</sub>	Gate Leakage Current	V <sub>GS</sub> = ± 20 V, V <sub>DS</sub> = 0 V			±100	nA
V <sub>GS(th)</sub>	Gate Threshold voltage	V <sub>DS</sub> = V <sub>GS</sub> , I <sub>D</sub> = 250 μA	1	1.6	3	V
R <sub>DS(ON)</sub>	Drain-Source on-state resistance	V <sub>GS</sub> = 10 V, I <sub>D</sub> = 30 A		0.42	0.5	mΩ
		V <sub>GS</sub> = 4.5 V, I <sub>D</sub> = 30 A		0.6	0.78	
<b>Dynamic Characteristics</b>						
C <sub>iss</sub>	Input Capacitance	V <sub>DS</sub> = 15 V, V <sub>GS</sub> = 0 V, f = 1 MHz		13210		pF
C <sub>oss</sub>	Output Capacitance			4055		pF
C <sub>rss</sub>	Reverse Transfer Capacitance			950		pF
R <sub>g</sub>	Gate Resistance	f = 1 MHz		2.6		Ω
<b>Switching Characteristics</b>						
t <sub>d(on)</sub>	Turn On Delay Time	V <sub>DD</sub> = 15 V, R <sub>L</sub> = 0.5 Ω, V <sub>GS</sub> = 10 V, R <sub>G</sub> = 3.3 Ω		20		ns
t <sub>r</sub>	Rise Time			64		ns
t <sub>d(off)</sub>	Turn Off Delay Time			226		ns
t <sub>f</sub>	Fall Time			167		ns
Q <sub>g</sub>	Total Gate Charge	V <sub>DD</sub> = 15 V, I <sub>D</sub> = 30 A, V <sub>GS</sub> = 10 V		240		nC
Q <sub>gs</sub>	Gate-Source Charge			40		nC
Q <sub>gd</sub>	Gate-Drain Charge			70		nC
<b>Drain-Source Diode Characteristics and Maximum Ratings</b>						
I <sub>S</sub>	Maximum Continuous Body-Diode Forward Current				430	A
I <sub>SM</sub>	Maximum Pulsed Body-Diode Forward Current				900	A
V <sub>SD</sub>	Diode Forward Voltage	V <sub>GS</sub> = 0 V, I <sub>S</sub> = 10 A		0.7		V
t <sub>rr</sub>	Reverse recovery time	V <sub>DD</sub> = 15 V, I <sub>D</sub> = 15 A, di/dt = 100 A/μS		95		ns
Q <sub>rr</sub>	Reverse recovery charge			150		nC
I <sub>rrm</sub>	Peak Reverse Recovery Current			2.7		A

# Electrical Characteristics Diagrams

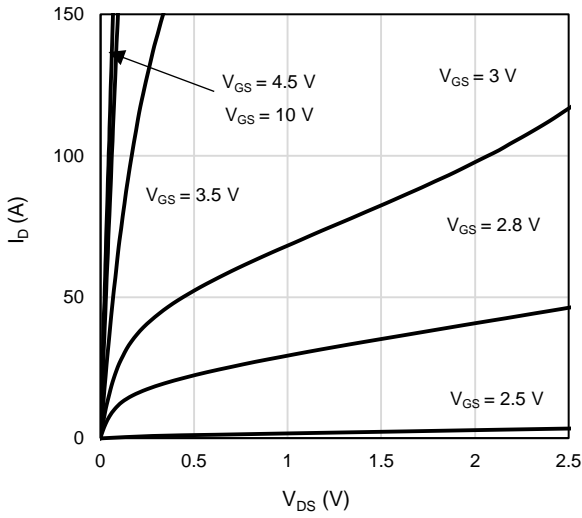

Figure 1: On-Region Characteristics

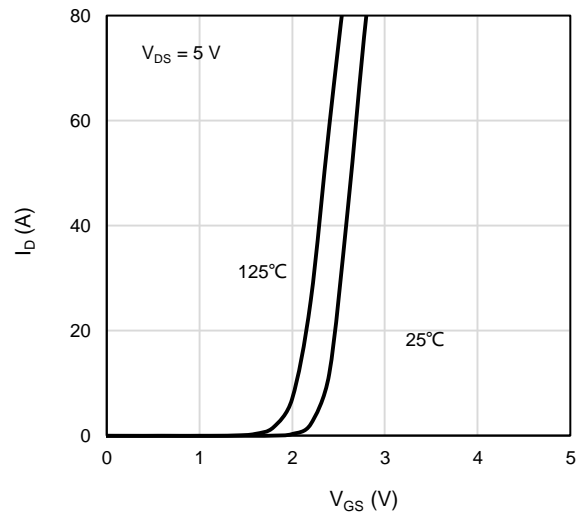

Figure 2: Transfer Characteristics

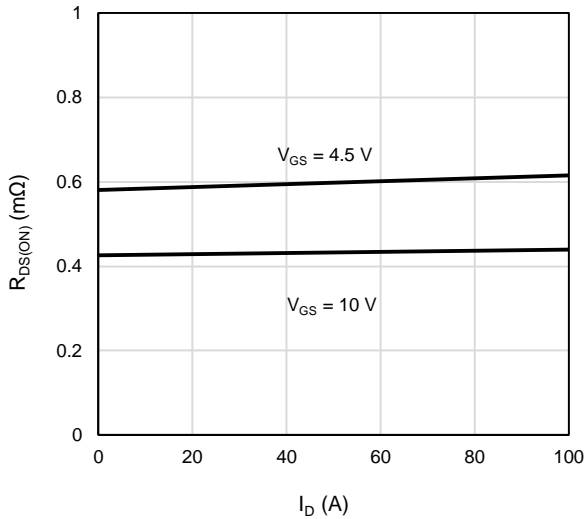

Figure 3: On-Resistance vs. Drain Current and Gate Voltage

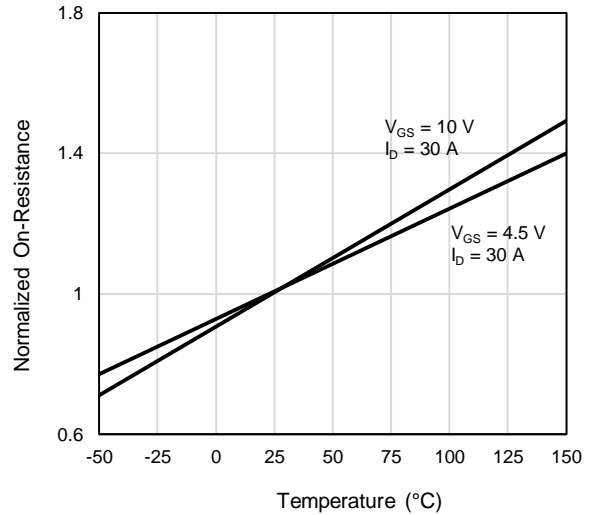

Figure 4: On-Resistance vs. Junction Temperature

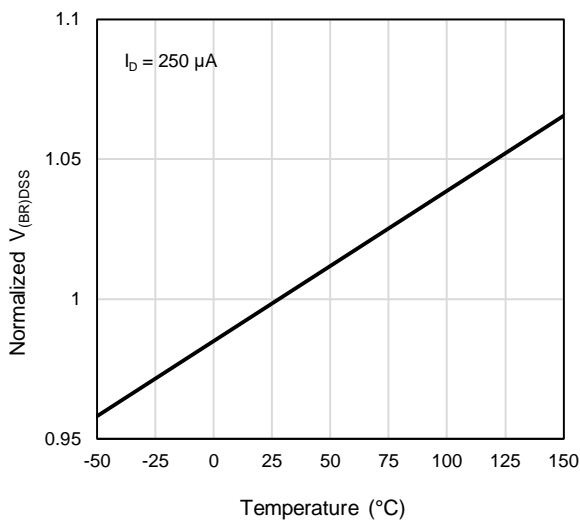

Figure 5: Breakdown Voltage vs. Junction Temperature

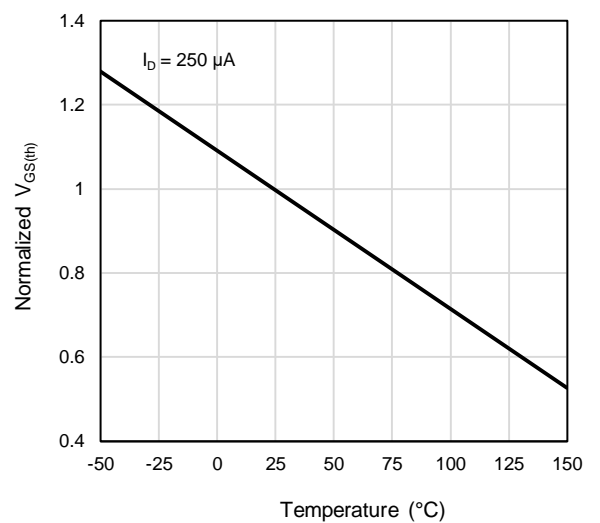

Figure 6: Threshold Voltage vs. Junction Temperature

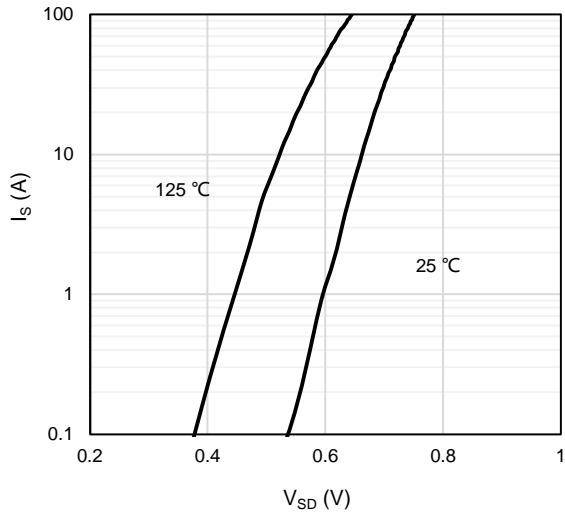

Figure 7: Body-Diode Characteristics

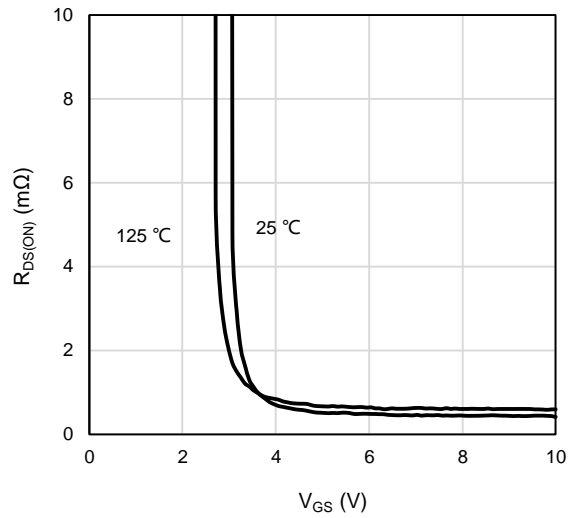

Figure 8: On-Resistance vs. Gate-Source Voltage

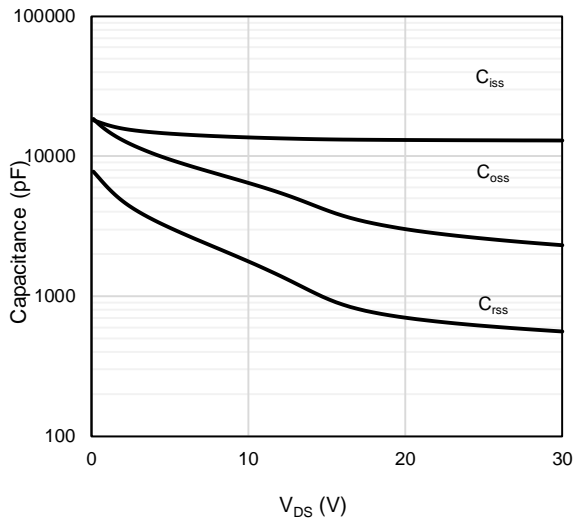

Figure 9: Capacitance Characteristics

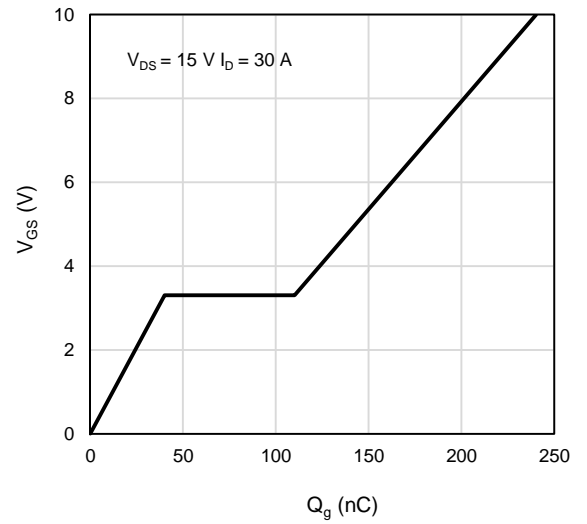

Figure 10: Gate-Charge Characteristics

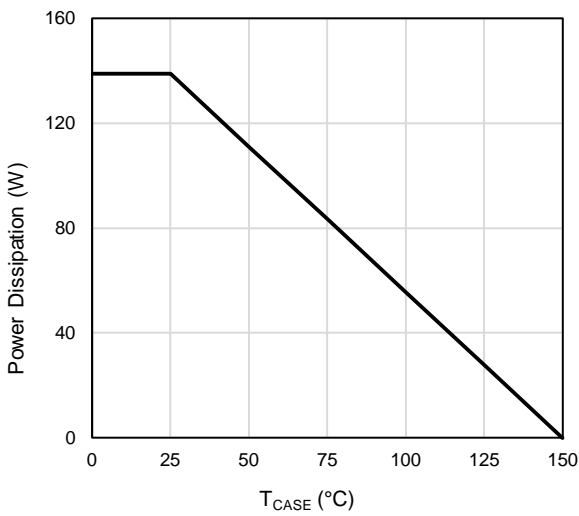

Figure 11: Power De-rating

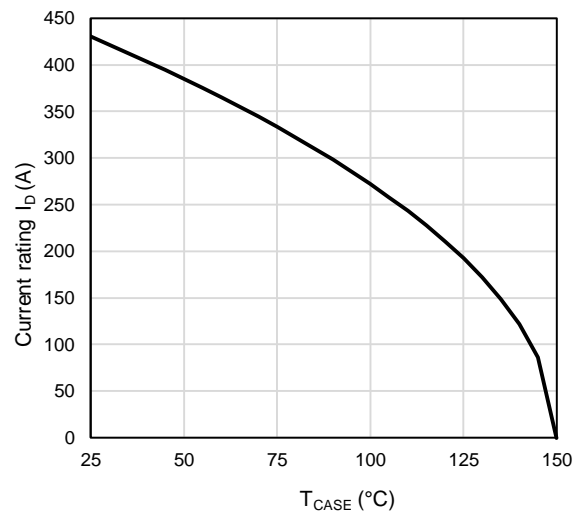

Figure 12: Current De-rating

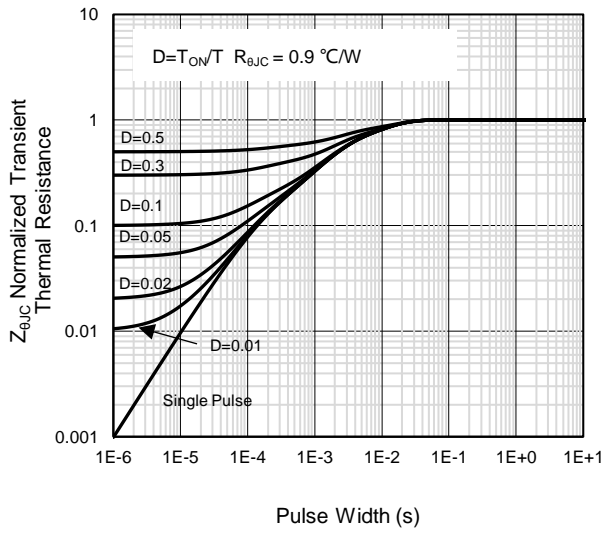

Figure 13: Normalized Maximum Transient Thermal Impedance

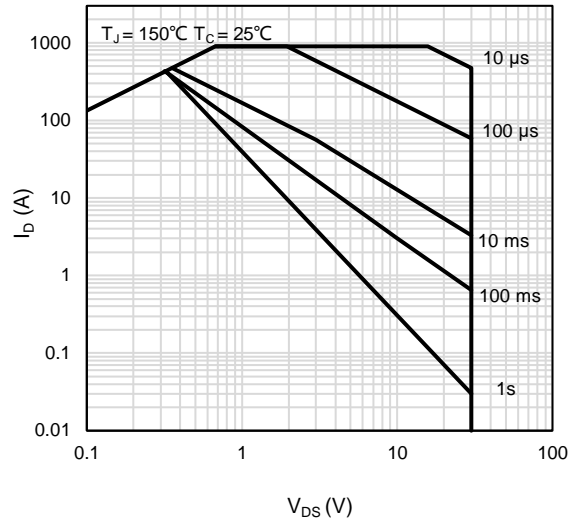
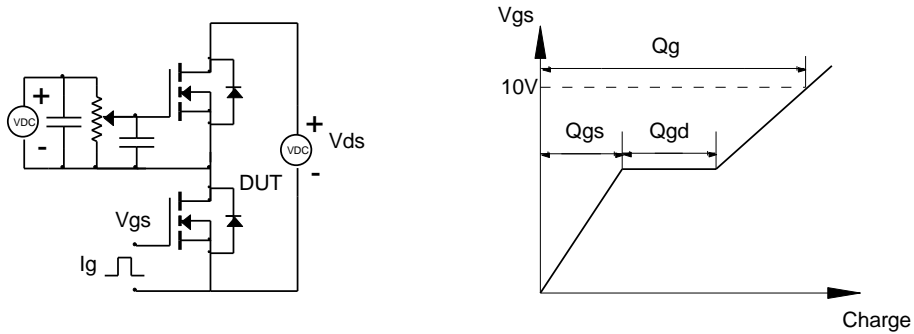

Figure 14: Maximum Forward Biased Safe Operating Area

# Test Circuit and Waveform

Gate Charge Test Circuit & Waveform



Resistive Switching Test Circuit & Waveforms

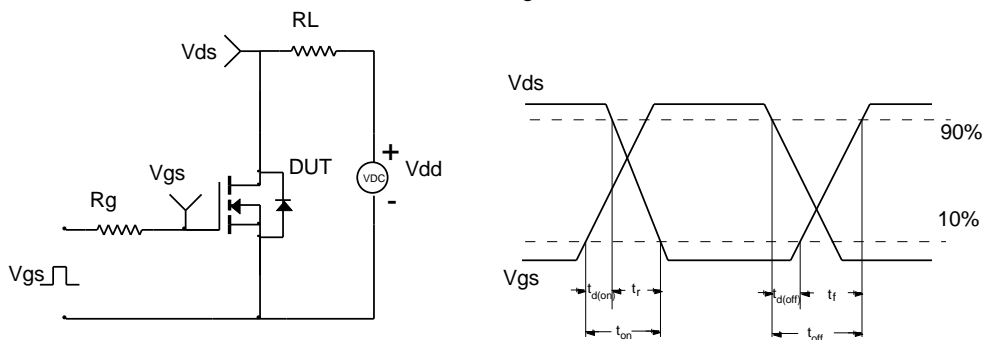

Unclamped Inductive Switching (UIS) Test Circuit & Waveforms

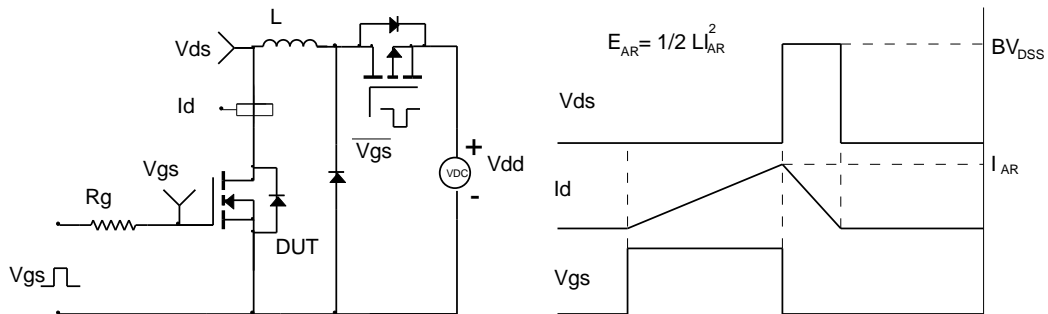

Diode Recovery Test Circuit & Waveforms

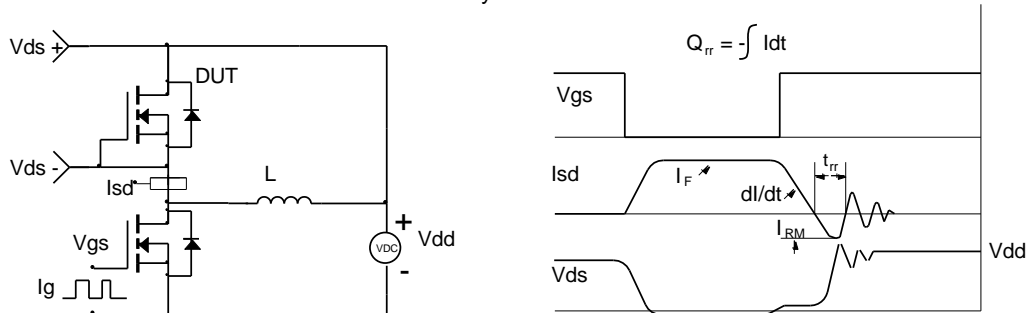

Package Outlines

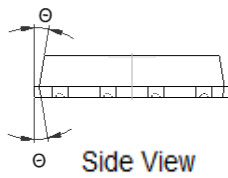
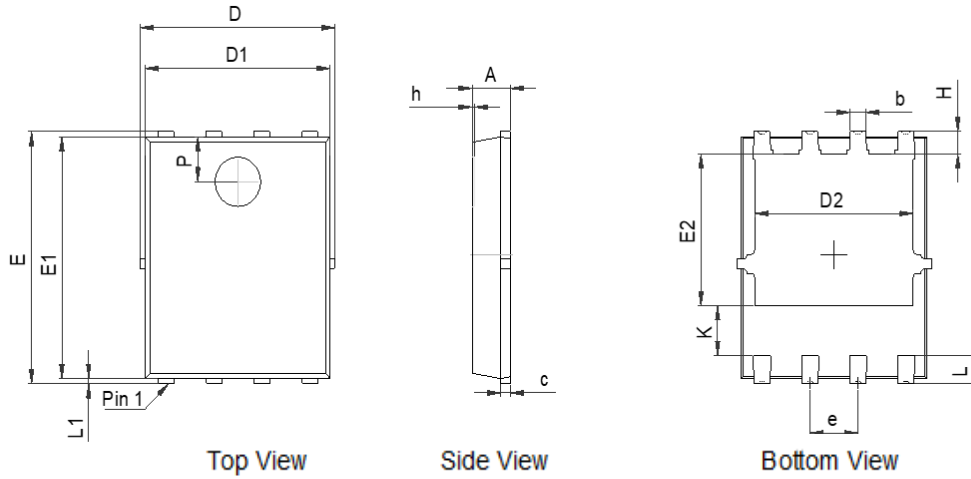

SYMBOL	MIN	NOM	MAX
A	0.90	1.00	1.10
b	0.32	0.42	0.52
c	0.21	0.25	0.34
D	5.00	5.15	5.30
D1	4.80	4.90	5.00
D2	4.10	4.20	4.30
e	1.27BSC		
E	6.00	6.15	6.30
E1	5.80	5.90	6.00
E2	3.60	3.70	3.80
H	0.45	0.55	0.65
h	-	-	0.10
K	1.17	-	-
L	0.58	0.68	0.78
L1	0.05	0.13	0.21
$\Theta$	8°	10°	12°
P	1.05	1.10	1.15

Unit in mm



### Marking Information

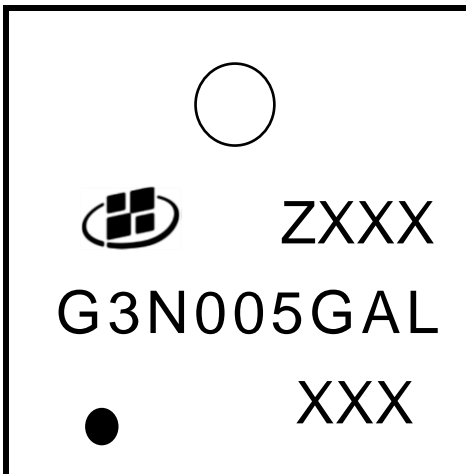

Note:

G3N005GAL = Product Name Code

ZXXX = Date code

XXX

Contact ALKAIDSEMI sales for detail information

### Tape & Reel Information

REEL DIMENSIONS

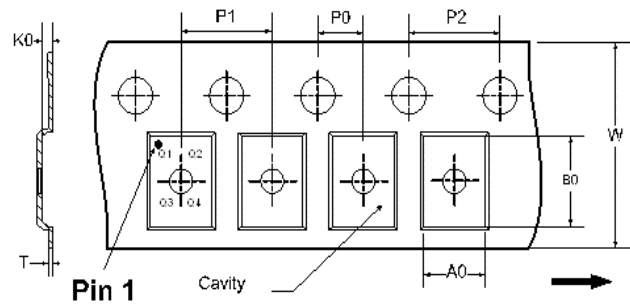
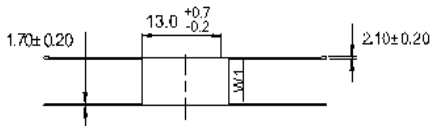
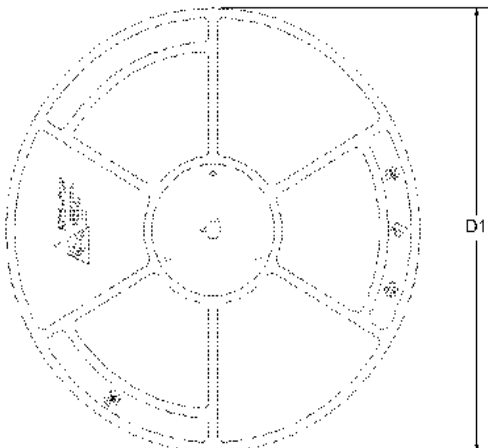

- A0: Dimension designed to accommodate the component width
- B0: Dimension designed to accommodate the component length
- K0: Dimension designed to accommodate the component thickness
- W: Overall width of the carrier tape
- P0: Pitch between successive cavity centers and sprocket hole
- P1: Pitch between successive cavity centers
- P2: Pitch between sprocket hole
- T: Tape material thickness
- D1: Reel Diameter
- W1: Reel Width

DIMENSIONS (Unit:mm)											
Reel	D1	W1									Material
	330	12.4									Hips
Tape	P0	P1	P2	W	A0	B0	K0	T	Pin 1 Quadrant	Material	
	2	8	4	12	6.45	5.45	1.2	0.25	Q1	PC	

---

**Revision History**

Revision	Released	Remark
Rev.1.0	2023	Initial Release

**Disclaimer**

The information given in this document describes the independent performance of the product, but similar performance is not guaranteed under other working conditions, and cannot be guaranteed when installed with other products or equipment. To achieve the required performance of the product in actual scenarios, the customer should conduct a complete application test to assess the functionality of the product.

Alkaidsemi assumes no responsibility for equipment failures result from using products at values that exceed the ratings, operating conditions, or other parameters listed in the product specifications.

The product described in this specification is not applicable for aerospace or other applications which requires high reliability. Customers using or selling these products for use in medical, life-saving, or life-sustaining applications do so at their own risk and agree to fully indemnify.

Due to product or technical improvements, the information described or contained herein may be changed without prior notice.